



**brands you trust.**

TECHNICAL DATASHEET  
**Pacific® CSV**  
**Cast Steel Valves**



Crane ChemPharma & Energy

[www.cranecpe.com](http://www.cranecpe.com)



## Gate, Globe and Check Features and Benefits



The new Pacific® CSV valves have been redesigned to improve performance and have undergone Crane's rigorous development and testing process. These valves exceed industry fugitive emissions standards. Each Pacific valve is uniquely built and tested per API 598 standards, delivering superior performance in the most challenging conditions.

### Certifications:

- API 624
- API RP 591
- API 622
- CE/PED
- Indian Boiler Regulation (IBR)
- ISO 15848-1
- ISO 9001:2008

These valves comply with the applicable requirements of the following standards:

- API 600
- API 623
- API 594
- API 598
- ASME B 16.34
- ASME B 16.10
- ASME B 16.5
- ASME B 16.25

### Gate Valve Features include:

- Fully-guided wedge ensures smooth operation in both horizontal and vertical orientations to deliver improved resistance to sticking.
- Modular stuffing box facilitates changeover for low fugitive emissions and monitoring port options.
- Live loading option extends fugitive emissions performance by eliminating the need for manual packing adjustment.

### Globe Valve Features include:

- Uniquely designed line contact between disc and seat results in lower seating torque, permitting faster set up.
- The guided disc option facilitates seating during turbulent flow conditions.
- Integral ISO 5210 mounting is available in larger sizes for ease of actuation.

### Swing Check Valve Features include:

- Disc fastener is restrained by the bonnet to eliminate the risk of a displaced disc and prevent damage to downstream equipment.
- Internal hung disc pin arrangement eliminates leak path from pressure boundary.
- Modular design enables easy change to an optional external pin arrangement if counterweights are required.



# Materials of Construction

Cast steel bolted bonnet valves described in this catalog are typically manufactured of carbon steel. When specified, the valves are available in the alloys shown below which are suitable for steam, water, oil, oil vapor, gas and general services. Please contact factory or customer service for availability and material breakdowns.

## Body and Bonnet or Cap Materials

Part No. Suffix	ASTM Classification	Material Classification	Service Conditions
A	A216 WCB	Carbon Steel	For service up to 800°F (426°C) where corrosion and oxidation are not a factor. (1) (4) (5)
E	A217 WC6	1 ¼ CR, ½ Mo	For service up to 1000°F (537°C). (2) (3) (4) (5)
F	A217 WC9	2 ¼ CR, 1 Mo	For service up to 1100°F (593°C) where good creep strength is required. (2) (3) (4) (5)
G	A217 C5	5% CR, ½ Mo	For service up to 1200°F (649°C). Better corrosion and oxidation resistance than other grades. (2)
H	A217 C12	9% CR, 1 Mo	For service up to 1200°F (649°C). Best corrosion and oxidation resistance than other grades. (2)
B C	A352 LCB LCC	Low Carbon Steel	For service from -20°F to 650°F (-29°C to 345°C). This material must be quenched and tempered to obtain tensile and impact properties needed at subzero temperatures.
J	A351 CF8M	Stainless Steel (316)	For services up to 1000°F (537°C), where corrosion and oxidation resistance are desired.
L	A351 CF8	Stainless Steel (304)	For services up to 1000°F (537°C), where corrosion and oxidation resistance are desired, but lower costs than CF8M and slightly lower material strengths and corrosion resistance can be tolerated.

(1) Upon prolonged exposure to temperatures above 800°F (426°C), the carbide phase of carbon steel may be converted to graphite. Permissible, but not recommended for prolonged usage above 800°F (426°C).

(2) Flanged end valves rated to 1000°F (537°C).

(3) Considerations should be given to the possibility of excessive oxidation (scaling) when used above 1050°F (565°C).

(4) Product used within the jurisdiction of Section 1 Power Boilers of the ASME Boiler and Pressure Vessel code is subject to the same temperature limitations as specified in that document.

(5) Product used within the jurisdiction of Power Piping, ASME Code for Pressure Piping B31.1, is subject to the same maximum temperature limitations placed upon the material in paragraph 124.2.

## Trim Material

Code	API Trim No.	Nominal Trim	Stem Material
N/A	1	Obsolete	
5	5	HF / HF (2)	13 Cr (410)
8	8*	F6 / HF (1) (2)	13 Cr (410)
9	9	Monel® / Monel® (4)	Monel
1	11	Monel® / HF (4) (2)	Monel®
2	12	316 / HF (3) (2)	316 SS
6	16	316/HF / 316/HF (3) (2)	316 SS

(1) 13% Chromium AISI Type 410 Stainless Steel.

(2) Hard Facing is weld deposited Cobalt base alloy.

(3) Austenitic Stainless Steel is a Ni-Cr-Mo stainless steel in the AISI Type 316 category.

(4) Ni-Cu Alloy.

\* Standard offering



# Gate Valve Materials of Construction

Item	Description	Carbon Steel
1	Body	ASTM A216, WCB
2	Seat Ring	ASTM A106 Gr. B, w/ AWS 5.13 CrCo
3	Disc	ASTM A216, WCB W/ AWS 5.9 ER410
4	Stem	ASTM 182, F6a
5	Gasket	Class 150: SS 316 Corr. Class 300: Spiral Wound SS Class 600: Ring Type
6	Bonnet	ASTM A216, WCB
7	Nut	ASTM A194, 2H
8	Stud	ASTM A193, B7
9	Backseat Bushing	ASTM A276, T410
10	Spacer	ASTM A276, T410
11	Packing	Graphite: 2 braided; 3 Die-Formed
12	Packing Gland	ASTM A276, T410
13	Grease Fitting	Steel
14	Handwheel Nut	ASTM A536, Gr.65-45-12
15	Pin	Zinc Plated Steel
16	Eye Bolt	ASTM A 194 2H
17	Gland Flange	ASTM A216 WCB
18	Packing Nuts	ASTM 307 Zinc Plated
19	Stem Nut	ASTM A439 Gr. D2
20	Retainer Nut	ASTM A536 Gr. 65-45-12
21	Handwheel	Carbon Steel/Ductile Iron

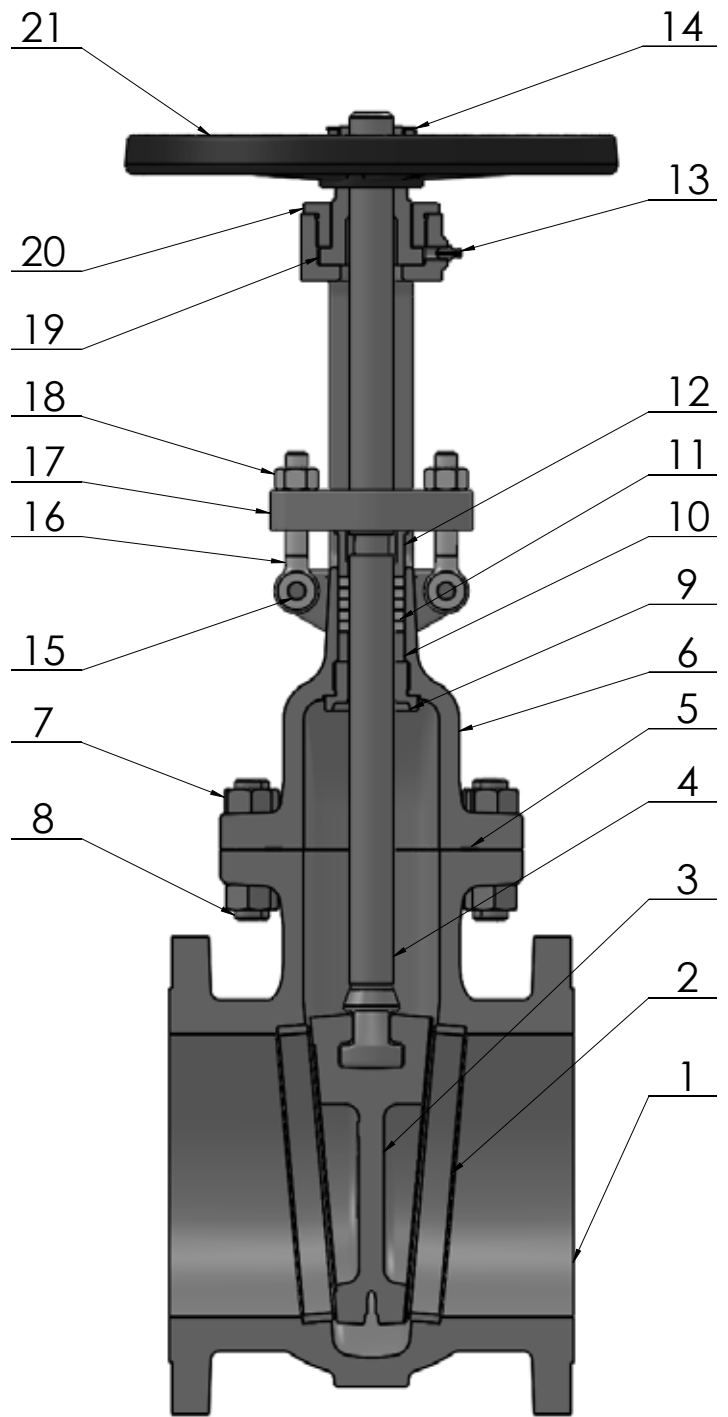

Standard construction WCB-Trim 8.  
Other options are available per Materials of Construction on page 14.

Figure A1- Class 150  
Figure A3- Class 300  
Figure A6- Class 600



# Gate Valve Dimensions and Weights

## CLASS 150, 300 & 600

Valve NB in (mm)	Pressure Class	L		H (Open)	H (Close)	M	Weight (lbs.)		Valve NB in (mm)	Pressure Class	L		H (Open)	H (Close)	M	Weight (lbs.)	
		FE	WE				FE	WE			FE	WE					
2" (50)	150	7	8.5	17	14	8	47	42	14" (350)	150	15	22.5	62	48	GO	842	816
	300	8.5	8.5	18	15	8	64	55		300	30	30	65	51	GO	1595	1340
	600	11.5	11.5	18.7	16	8	85	72		600	35	35	65	51	GO	2618	2285
2.5" (65)	150	7.5	9.5	17	14	8	56	48	16" (400)	150	16	24	70	54.41	GO	1094	1032
	300	9.5	9.5	18	15	8	73	59		300	33	33	73	56	GO	2040	1813
	600	13	13	20	17	9	118	98		600	39	39	79	63	GO	3715	3245
3" (80)	150	8	11.12	20	16	9	75	66	18" (450)	150	17	26	76	58	GO	1389	1418
	300	11.12	11.12	21	17	9	110	91		300	36	36	80	62	GO	2638	2252
	600	14	14	24	20	10	138	113		600	43	43	84	66	GO	4490	3911
4" (100)	150	9	12	24	20	10	106	97	20" (500)	150	18	28	86	66	GO	1654	1601
	300	12	12	25	20	10	165	136		300	39	39	90	70	GO	3564	3089
	600	17	17	28	23	14	250	197		600	47	47	93	72	GO	6213	5476
6" (150)	150	10.5	15.88	31	25	14	185	179	24" (600)	150	20	32	99	75	GO	2396	2334
	300	15.88	15.88	33	26	14	310	256		300	45	45	101	77	GO	5338	4625
	600	22	22	36	29	18	584	472		600	55	55	110	86	GO	9385	8342
8" (200)	150	11.5	16.5	39	30	14	278	263	24" (600)	150	18	28	86	66	GO	1654	1601
	300	16.5	16.5	41	32	16	481	400		300	39	39	90	70	GO	3564	3089
	600	26	26	43	35	20	936	793		600	47	47	93	72	GO	6213	5476
10" (250)	150	13	18	46	36	16	411	396	24" (600)	150	20	32	99	75	GO	2396	2334
	300	18	18	50	39	18	737	614		300	45	45	101	77	GO	5338	4625
	600	31	31	54	43	GO	1502	1235		600	55	55	110	86	GO	9385	8342
12" (300)	150	14	19.75	55	42	18	622	593	24" (600)	150	20	32	99	75	GO	2396	2334
	300	19.75	19.75	57	44	20	1036	895		300	45	45	101	77	GO	5338	4625
	600	33	33	62	48	GO	2043	1740		600	55	55	110	86	GO	9385	8342

FE: Flanged End Valve  
 WE: Buttweild End Valve  
 H (open): Valve center to Stem top in Valve open condition  
 H (close): Valve center to Stem top in Valve close condition  
 L: Face to Face dimension  
 M: Handwheel Diameter  
 GO: Gear Operator

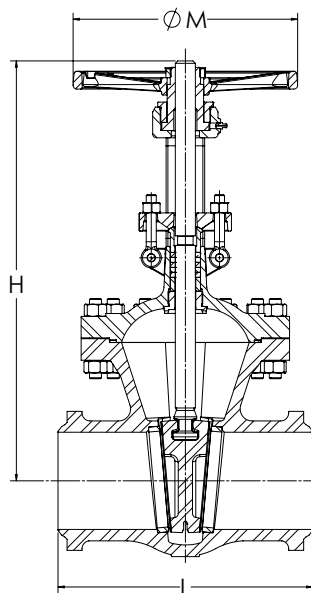
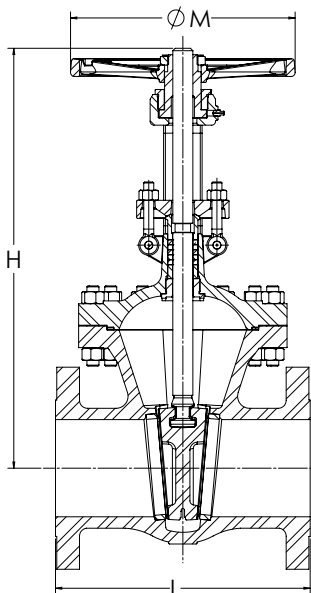

Figure A1- Class 150  
 Figure A3- Class 300  
 Figure A6- Class 600



# Globe Valve Materials of Construction

Item	Description	Carbon Steel
1	Body	ASTM A216. WCB
2	Seat Ring	A105 w/AWS 5.13 CrCo or WCB w/AWS 5.13 CrCo
3	Disc	ASTM A216. GR WCB. w/AWS 5.9 ER 410
4	Thrust Plate	ASTM A216. WCB
5	Stem	ASTM 182. F6a
6	Disc Nut	ASTM A276. T410
7	Gasket	Class 150: Spiral Wound SS Class 300: Sprial Wound SS Class 600: Ring Type
8	Bonnet	ASTM A216, WCB
9	Backseat	ASTM A276, T410
10	Packing Spacer	ASTM A276, T410
11	Packing	Graphite: 2 braided; 3 Die-Formed
12	Gland	ASTM A276, T410
13	Gland Flange	ASTM A216, WCB
14	Pin	Zinc Plated Steel
15	Eye Bolt	ASTM A307 Gr. A or Gr. B, Zinc Plt.
16	Nut	ASTM A194, 2H
17	Stud	ASTM A193, B7
18	Handwheel	Carbon Steel/Ductile Iron
19	Yoke Sleeve	ASTM A439, Gr. D2
20	Handwheel Nut	ASTM A194, 2H
21	Eyebolt Nut	ASTM A196 Gr. 24

Figure B1- Class 150  
Figure B3- Class 300  
Figure B6- Class 600

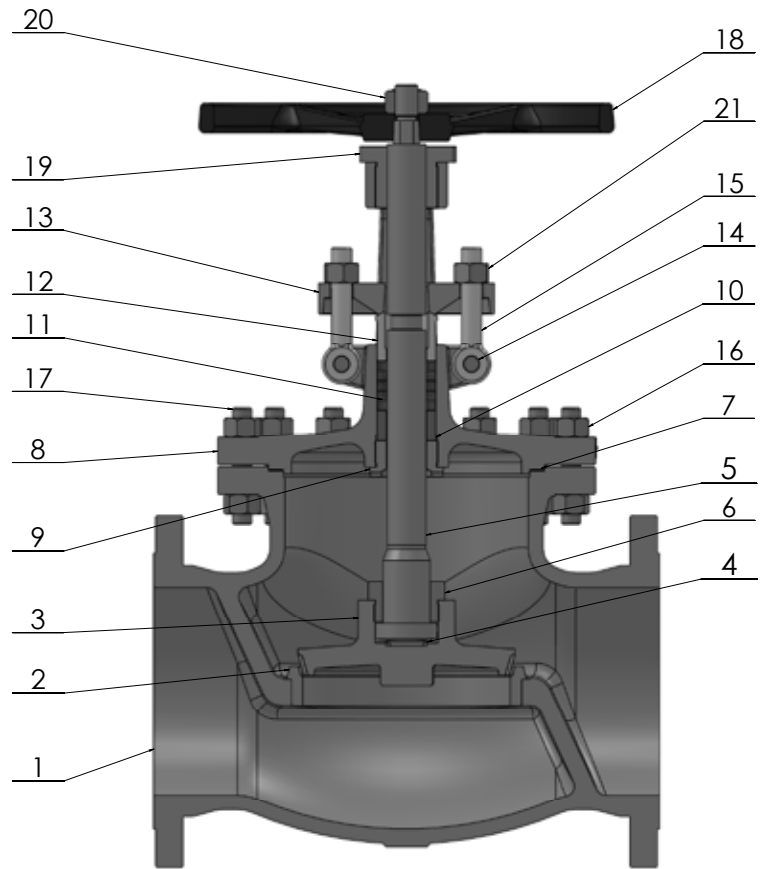

Standard construction WCB-Trim 8.  
Other options are available per Materials of construction on page 14.



# Globe Valve Dimensions and Weights

## CLASS 150, 300 & 600

Valve NB in (mm)	Pressure Class	L		H (Open)	H (Close)	M	Weight (lbs.)		Valve NB in (mm)	Pressure Class	L		H (Open)	H (Close)	M	Weight (lbs.)	
		FE	WE				FE	WE			FE	WE					
2" (50)	150	8	8	16	15	8	50	45	10" (250)	150	24.5	24.5	29	25	GO	505	453
	300	10.5	10.5	16	15	8	57	49		300	24.5	24.5	36	31.4	23.6	825	720
	600	11.5	11.5	16.7	15.7	8	93	80		600	31	31	45	41	GO	1610	1340
2.5" (65)	150	8.5	8.5	16.5	15.5	8	71	54	12" (300)	150	27.5	27.5	34	28.5	GO	724	643
	300	11.5	11.5	18	16.5	8	86	72		300	28	28	41.4	36	23.6	1184	1015
	600	13	13	19.3	18	10	130	107		600	33	33	56	50	GO	2264	1966
3" (80)	150	9.5	9.5	18	17	10	88	74	14" (350)	150	31	31	40.6	36.7	GO	1115	990
	300	12.5	12.5	18	16.5	10	107	88		300	33	33	47.4	41.7	GO	1739	1485
	600	14	14	21	20	10	185	164									
4" (100)	150	11.5	11.5	22	20.5	10	133	116	16" (400)	150	36	36	43.6	38.4	GO	1399	1250
	300	14	14	23	21	10	178	146		300	34	34	59	51	GO	2386	2113
	600	17	17	26	24.5	16	311	256									
6" (150)	150	16	16	22	21	14	196	172	18" (450)	150	38.5	38.5	45	39	GO	1724	1584
	300	17.5	17.5	28	25	18	350	299		300	38.5	38.5	60.4	54	GO	3105	2740
	600	22	22	33	30.6	20	728	618									
8" (200)	150	19.5	19.5	27	23	16	330	295									
	300	22	22	31	27	20	561	488									
	600	26	26	39	36	26	1269	1114									

FE: Flanged End Valve  
 WE: Butt-weld End Valve  
 H (open): Valve center to Stem top in Valve open condition  
 H (close): Valve center to Stem top in Valve close condition  
 L: Face to Face dimension  
 M: Handwheel Diameter  
 GO: Gear Operator

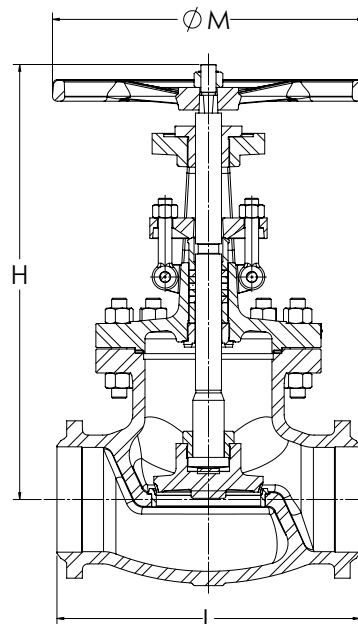
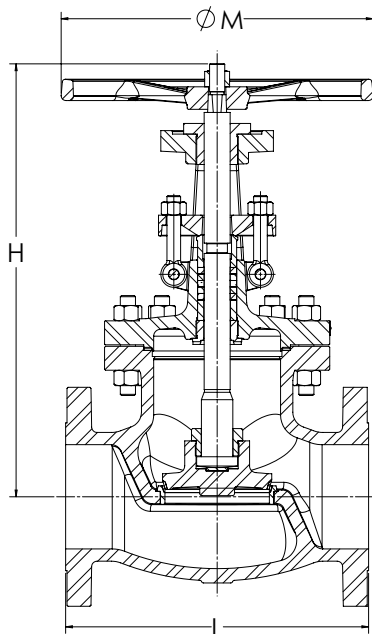

Figure B1- Class 150  
 Figure B3- Class 300  
 Figure B6- Class 600



# Swing Check Materials of Construction

Item	Description	Carbon Steel
1	Body	ASTM A216, WCB
2	Seat Ring	ASTM A106 Gr. B, w/ AWS 5.13 CrCo [350 - 400 HB]
3	Disc	ASTM A216, GR WCB. w/AWS 5.9 ER 410
4	Hinge	ASTM A216 WCB
5	Washer	ASTM A276, T410
6	Disc Nut	ASTM A194, Gr. 2H
7	Hinge Pin	ASTM A276, T410
8	Hinge Bracket	ASTM A216, WCB
9	Cap Screw	ASTM A193, B7
10	Gasket	Class 150: Spiral Wound SS Class 300: Spiral Wound SS Class 600: Ring Type
11	Cap	ASTM A216, WCB
12	Cap Studs	ASTM A194, Gr. 2H
13	Cap Nuts	ASTM A 193, B7
14	Split Pin	ASTM A 108 C1030

Standard construction WCB-Trim 8.  
Other options are available per Materials of construction on page 14.

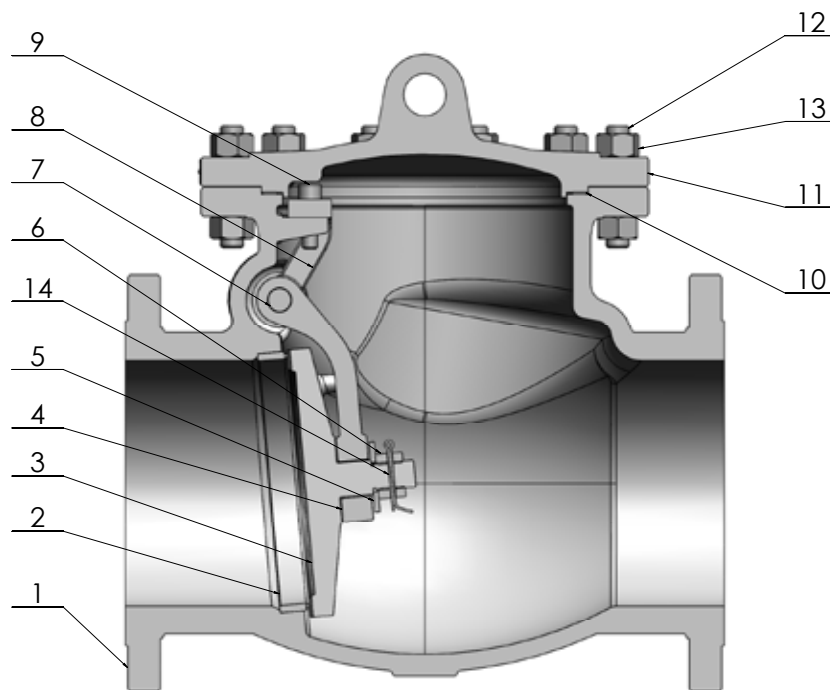

Figure C1- Class 150  
Figure C3- Class 300  
Figure C6- Class 600





# Swing Check Dimensions and Weights

## CLASS 150, 300 & 600

Valve NB in (mm)	Pressure Class	L	H (Open)	Weight (lbs.)		Valve NB in (mm)	Pressure Class	L	H (Open)	Weight (lbs.)	
		FE/WE		FE	WE			FE/WE		FE	WE
2" (50)	150	8	6	32	25	14" (350)	150	31	22	866	741
	300	10.5	6	43	33		300	33	22	1385	1131
	600	11.5	7	71	57		600	35	25	2228	1896
2.5" (65)	150	8.5	6	45	34	16" (400)	150	36	25	1138	981
	300	11.5	7	66	52		300	34	25	1625	1351
	600	13	8	100	80		600	39	29	2919	2449
3" (80)	150	9.5	7	62	47	18" (450)	150	38.5	25	1560	1419
	300	12.5	7	87	68		300	38.5	27	2212	1808
	600	14	8	101	82		600	43	35	3820	3240
4" (100)	150	11.5	8	92	75	20" (500)	150	38.5	25	1770	1551
	300	14	12	132	101		300	40	27	2831	2376
	600	17	12	211	153		600	47	35	4776	4038
6" (150)	150	16	12	148	124	24" (600)	150	51	25	2455	2154
	300	17.5	14	267	215		300	53	27	4171	3461
	600	22	15	475	364		600	55	40	7661	6620
8" (200)	150	19.5	14	273	233	FE: Flanged End Valve WE: Buttweild End Valve H: Valve center to valve cap highest point L: Face to Face dimension					
	300	21	15	438	355						
	600	26	18	801	656						
10" (250)	150	24.5	16	401	351						
	300	24.5	18	633	515						
	600	31	21	1173	922						
12" (300)	150	27.5	18	593	512						
	300	28	20	898	728						
	600	33	24	1677	1390						

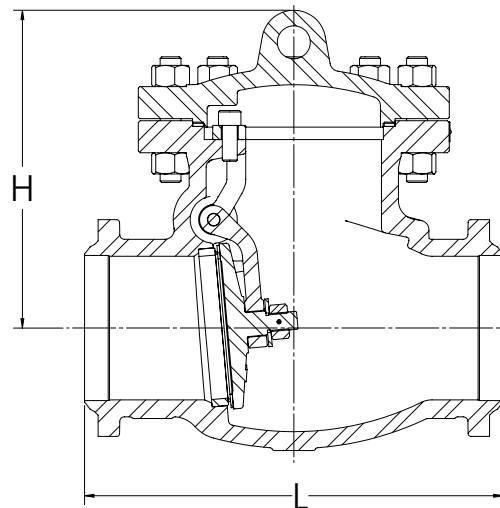
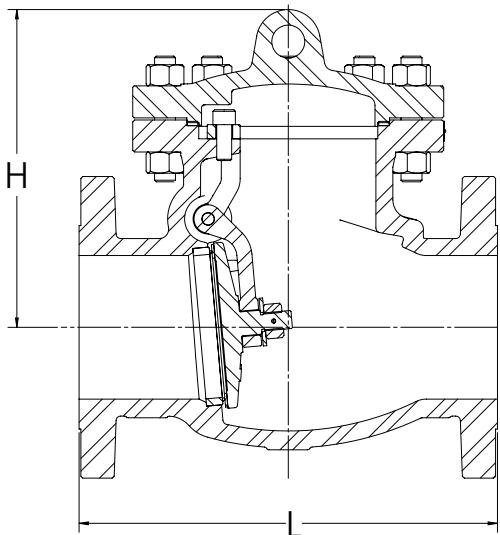

Figure C1- Class 150  
 Figure C3- Class 300  
 Figure C6- Class 600



# Gate Valve Cv and Torque

## Gate Valves - Cv

Size	Class 150		Class 300		Class 600	
	Cv	Kv	Cv	Kv	Cv	Kv
2	324	281	325	281	306	265
2.5	515	445	515	445	491	425
3	757	655	757	655	728	630
4	1374	1188	1345	1163	1334	1154
6	3162	2735	3162	2735	3084	2668
8	5790	5008	5705	4935	5527	4781
10	9287	8034	9251	8002	8797	7610
12	13321	11523	13321	11523	12776	11052
14	16241	14049	16241	14049	15332	13263
16	22398	19375	22409	19385	20953	18126
18	28657	24790	27826	24071	26213	22676
20	35686	30870	34758	30068	32075	27747
24	54371	47033	53199	46019	48673	42105

## Gate Valves - Torque

Size	Pressure Class	Differential Pressure (psi)	Stem Diameter (in)	Stem Travel (in)	Torque (ft-lbs.)
2	150	325	0.75	2.4	6
	300	825	0.75	3.2	11
	600	1650	0.75	2.7	18
2.5	150	325	0.75	2.9	7
	300	825	0.75	3	13
	600	1650	0.875	3.1	29
3	150	325	0.875	3.4	10
	300	825	0.875	3.9	20
	600	1650	1	3.7	46
4	150	325	1	4.5	18
	300	825	1	5	37
	600	1650	1.125	4.6	80
6	150	325	1.125	6.6	35
	300	825	1.25	6.6	89
	600	1650	1.5	6.4	219
8	150	325	1.25	8.3	61
	300	825	1.375	8.3	167
	600	1650	1.625	8.2	373
10	150	325	1.375	10.5	103
	300	825	1.5	10.6	268
	600	1650	1.875	11.2	628
12	150	325	1.5	12.7	154
	300	825	1.625	12.4	402
	600	1650	2	13.1	932
14	150	325	1.625	13.7	198
	300	825	1.75	14	517
	600	1650	2.25	13.9	1302
16	150	325	1.75	16.1	273
	300	825	1.875	17.1	715
	600	1650	2.375	15.9	1848
18	150	325	1.875	18.3	365
	300	825	2	17.8	957
	600	1650	2.5	18.1	2265
20	150	325	2	20	475
	300	825	2.25	20.3	1381
	600	1650	2.75	21.1	2993
24	150	325	2.25	24.1	793
	300	825	2.5	23.9	2171
	600	1650	3	23.3	5736



# Globe & Swing Check Valve Cv and Torque

## Globe Valves - Cv

Size	Class 150		Class 300		Class 600	
	Cv	Kv	Cv	Kv	Cv	Kv
2	47	41	47	41	47	41
2.5	75	65	75	65	75	65
3	111	96	111	96	111	96
4	206	178	206	178	206	178
6	479	415	479	415	479	415
8	873	756	873	756	873	756
10	1419	1227	1419	1227	1353	1170
12	2046	1770	1650	1427	1960	1695
14	2491	2155	2490	2154	NA	NA
16	3435	2971	3435	2971	NA	NA
18	4402	3808	4268	3692	NA	NA

## Swing Check Valve - Cv

Size	Class 150		Class 300		Class 600	
	Cv	Kv	Cv	Kv	Cv	Kv
2	123	107	123	107	122	106
2.5	197	170	197	170	197	170
3	291	252	291	252	291	252
4	538	465	538	465	538	465
6	1240	1073	1240	1073	1240	1073
8	2278	1970	2278	1970	2211	1912
10	3700	3201	3700	3201	3519	3044
12	5335	4615	5335	4615	5110	4421
14	6498	5621	6496	5620	6133	5305
16	8964	7754	8964	7754	8381	7250
18	11463	9916	11141	9637	10485	9070
20	14274	12348	13903	12027	12830	11099
24	21748	18813	21272	18401	19469	16842

## Globe Valves - Torque

Size (in.)	Pressure Class	Differential Pressure (psi)	Stem Diameter (in)	Stem Travel (in)	Torque (ft-lbs)
2	150	325	0.875	0.9	12
	300	825	0.875	0.9	25
	600	1650	0.875	0.9	46
2.5	150	325	0.875	1	17
	300	825	0.875	1.5	37
	600	1650	1	1.3	81
3	150	325	1	1.2	27
	300	825	1	1.3	60
	600	1650	1.25	1.2	138
4	150	325	1.25	1.4	53
	300	825	1.25	1.9	124
	600	1650	1.25	1.5	239
6	150	325	1.25	1.6	110
	300	825	1.5	3.2	327
	600	1650	1.875	2.5	772
8	150	325	1.5	3.2	232
	300	825	1.75	3.9	649
	600	1650	2.5	3.3	1762
10	150	325	1.5	3.8	357
	300	825	2.25	4.5	1308
	600	1650	3.25	3.9	3603
12	150	325	1.75	5.5	577
	300	825	2.75	5.3	2214
	600	1650	3.5	5.8	5534
14	150	325	1.875	3.9	742
	300	825	2.875	5.6	3019
16	150	325	2.25	5.2	1201
	300	825	3.5	7.9	4670
18	150	325	2.5	6.1	1669
	300	825	4	6.3	6469



# Pressure / Temperature Range

The following pressure-temperature charts are derived from ASME B16.34 – 2013 Version. They will cover the most commonly used body and bonnet materials in the industry. All Crane Valves are designed to operate through the pressure and temperature ranges shown in these charts for a particular ASME Class Rating and ASTM Material.

## ASTM A216 GR WCB

°F	STANDARD CLASS B16.34 - 2013						SPECIAL CLASS B16.34 - 2013					
	MAXIMUM NON-SHOCK WORKING PRESSURE, PSIG						MAXIMUM NON-SHOCK WORKING PRESSURE, PSIG					
	150	300	600	900	1500	2500	150	300	600	900	1500	2500
-20 to 100	285	740	1480	2220	3705	6170	290	750	1500	2250	3750	6250
200	260	680	1360	2035	3395	5655	290	750	1500	2250	3750	6250
300	230	655	1310	1965	3270	5450	285	740	1480	2220	3700	6170
400	200	635	1265	1900	3170	5280	280	735	1465	2200	3665	6105
500	170	605	1205	1810	3015	5025	280	735	1465	2200	3665	6105
600	140	570	1135	1705	2840	4730	280	735	1465	2200	3665	6105
650	125	550	1100	1650	2745	4575	275	715	1430	2145	3575	5960
700	110	530	1060	1590	2665	4425	265	690	1380	2075	3455	5760
750	95	505	1015	1520	2535	4230	245	635	1270	1905	3170	5285
800	80	410	825	1235	2055	3430	195	515	1030	1545	2570	4285

NOTE: Upon prolonged exposure to temperatures above 800°F (426°C), the carbide phase of steel may be converted to graphite. Permissible, but not recommended for prolonged use above 800°F (426°C).

## ASTM A352 GR LCB

°F	STANDARD CLASS B16.34 - 2013						SPECIAL CLASS B16.34 - 2013					
	MAXIMUM NON-SHOCK WORKING PRESSURE, PSIG						MAXIMUM NON-SHOCK WORKING PRESSURE, PSIG					
	150	300	600	900	1500	2500	150	300	600	900	1500	2500
-20 to 100	265	695	1395	2090	3480	5805	290	695	1395	2090	3480	5805
200	255	660	1320	1980	3300	5505	290	695	1395	2090	3480	5805
300	230	640	1275	1915	3190	5315	290	695	1395	2090	3480	5805
400	200	615	1230	1845	3075	5125	290	695	1395	2090	3480	5805
500	170	585	1175	1760	2930	4885	290	695	1395	2090	3480	5805
600	140	550	1105	1655	2755	4595	290	695	1395	2090	3480	5805
650	125	535	1065	1600	2665	4440	290	695	1390	2080	3470	5780

NOTE: Not to be used over 650°F (343°C).

## ASTM A352 GR LCC & LC3

°F	STANDARD CLASS B16.34 - 2013						SPECIAL CLASS B16.34 - 2013					
	MAXIMUM NON-SHOCK WORKING PRESSURE, PSIG						MAXIMUM NON-SHOCK WORKING PRESSURE, PSIG					
	150	300	600	900	1500	2500	150	300	600	900	1500	2500
-20 to 100	290	750	1500	2250	3750	6250	290	750	1500	2250	3750	6250
200	260	750	1500	2250	3750	6250	290	750	1500	2250	3750	6250
300	230	730	1455	2185	3640	6070	290	750	1500	2250	3750	6250
400	200	705	1405	2110	3520	5865	290	750	1500	2250	3750	6250
500	170	665	1330	1995	3325	5540	290	750	1500	2250	3750	6250
600	140	605	1210	1815	3025	5040	290	750	1500	2250	3750	6250
650	125	590	1175	1765	2940	4905	290	750	1500	2250	3750	6250

NOTE: Not to be used over 650°F (343°C).

\* "Special Class" applies to weld-end valves only and requires NDE testing in accordance with ASME B16.34 - 2013.



# Pressure / Temperature Range

## ASTM A217 GR WC6

°F	STANDARD CLASS B16.34 - 2013						SPECIAL CLASS B16.34 - 2013					
	MAXIMUM NON-SHOCK WORKING PRESSURE, PSIG						MAXIMUM NON-SHOCK WORKING PRESSURE, PSIG					
	150	300	600	900	1500	2500	150	300	600	900	1500	2500
-20 to 100	290	750	1500	2250	3750	6250	290	750	1500	2250	3750	6250
200	260	750	1500	2250	3750	6250	290	750	1500	2250	3750	6250
300	230	720	1445	2165	3610	6015	290	750	1500	2250	3750	6250
400	200	695	1385	2080	3465	5775	290	750	1500	2250	3750	6250
500	170	665	1330	1995	3325	5540	290	750	1500	2250	3750	6250
600	140	605	1210	1815	3025	5040	290	750	1500	2250	3750	6250
650	125	590	1175	1765	2940	4905	290	750	1500	2250	3750	6250
700	110	570	1135	1705	2840	4730	280	735	1465	2200	3665	6110
750	95	530	1065	1595	2660	4430	280	730	1460	2185	3645	6070
800	80	510	1015	1525	2540	4230	275	720	1440	2160	3600	6000
850	65	485	975	1460	2435	4060	260	680	1355	2030	3385	5645
900	50	450	900	1350	2245	3745	225	585	1175	1760	2935	4895
950	35	320	640	955	1595	2655	155	400	795	1195	1995	3320
1000	20	215	430	650	1080	1800	105	270	540	810	1350	2250
1050	20(a)	145	290	430	720	1200	70	180	360	540	900	1500
1100	20(a)	95	190	290	480	800	45	120	240	360	600	1000

NOTE: Use normalized and tempered material only. Not to be used over 1100°F (593°C). The deliberate addition of any element not listed in ASTM A217, Table 1 is prohibited, except that Ca and Mg may be added for deoxidation.

(a) Flanged end valve ratings terminate at 1000°F (537°C).

## ASTM A217 GR WC9

°F	STANDARD CLASS B16.34 - 2013						SPECIAL CLASS B16.34 - 2013					
	MAXIMUM NON-SHOCK WORKING PRESSURE, PSIG						MAXIMUM NON-SHOCK WORKING PRESSURE, PSIG					
	150	300	600	900	1500	2500	150	300	600	900	1500	2500
-20 to 100	290	750	1500	2250	3750	6250	290	750	1500	2250	3750	6250
200	260	750	1500	2250	3750	6250	290	750	1500	2250	3750	6250
300	230	730	1455	2185	3640	6070	285	740	1480	2220	3695	6160
400	200	705	1410	2115	3530	5880	280	730	1455	2185	3640	6065
500	170	665	1330	1995	3325	5540	280	725	1450	2175	3620	6035
600	140	605	1210	1815	3025	5040	275	720	1440	2165	3605	6010
650	125	590	1175	1765	2940	4905	275	715	1430	2145	3580	5965
700	110	570	1135	1705	2840	4730	270	705	1415	2120	3535	5895
750	95	530	1065	1595	2660	4430	270	705	1415	2120	3535	5895
800	80	510	1015	1525	2540	4230	270	705	1415	2120	3535	5895
850	65	485	975	1460	2435	4060	260	680	1355	2030	3385	5645
900	50	450	900	1350	2245	3745	230	600	1200	1800	3000	5000
950	35	385	755	1160	1930	3220	180	470	945	1415	2360	3930
1000	20	265	535	800	1335	2230	130	335	670	1005	1670	2785
1050	20(a)	175	350	525	875	1455	85	220	435	655	1095	1820
1100	20(a)	110	220	330	550	915	55	135	275	410	685	1145

NOTE: Use normalized and tempered material only. Not to be used over 1100°F (593°C). The deliberate addition of any element not listed in ASTM A217, Table 1 is prohibited, except that Ca and Mg may be added for deoxidation.

(a) Flanged end valve ratings terminate at 1000°F (537°C).



# Pressure / Temperature Range

## ASTM A217 GR C5

°F	STANDARD CLASS B16.34 - 2013						SPECIAL CLASS B16.34 - 2013					
	MAXIMUM NON-SHOCK WORKING PRESSURE, PSIG						MAXIMUM NON-SHOCK WORKING PRESSURE, PSIG					
	150	300	600	900	1500	2500	150	300	600	900	1500	2500
-20 to 100	290	750	1500	2250	3750	6250	290	750	1500	2250	3750	6250
200	260	750	1500	2250	3750	6250	290	750	1500	2250	3750	6250
300	230	730	1445	2185	3640	6070	290	750	1500	2250	3750	6250
400	200	705	1410	2115	3530	5880	290	750	1500	2250	3750	6250
500	170	665	1330	1995	3325	5540	290	750	1500	2250	3750	6250
600	140	605	1210	1815	3025	5040	290	750	1500	2250	3750	6250
650	125	590	1175	1765	2940	4905	290	750	1500	2250	3750	6250
700	110	570	1135	1705	2840	4730	280	735	1465	2200	3665	6110
750	95	530	1065	1595	2660	4430	280	730	1460	2185	3645	6070
800	80	510	1015	1525	2540	4230	275	720	1440	2160	3600	6000
850	65	485	975	1460	2435	4060	260	615	1225	1840	3065	5105
900	50	375	745	1120	1870	3115	230	465	935	1400	2335	3895
950	35	275	550	825	1370	2285	170	345	685	1030	1715	2855
1000	20	200	400	595	995	1655	125	250	495	745	1245	2070
1050	20(a)	145	290	430	720	1200	90	180	360	540	900	1500
1100	20(a)	100	200	300	495	830	60	125	250	375	620	1035
1150	20(a)	60	125	185	310	515	40	75	155	230	385	645
1200	15(a)	35	70	105	170	285	20	45	85	130	215	355

NOTE: Use normalized and tempered material only. The deliberate addition of any element not listed in ASTM A217, Table 1 is prohibited, except that Ca and Mg may be added for deoxidation.

(a) Flanged end valve ratings terminate at 1000°F (537°C).

## ASTM A217 GR C12

°F	STANDARD CLASS B16.34 - 2013						SPECIAL CLASS B16.34 - 2013					
	MAXIMUM NON-SHOCK WORKING PRESSURE, PSIG						MAXIMUM NON-SHOCK WORKING PRESSURE, PSIG					
	150	300	600	900	1500	2500	150	300	600	900	1500	2500
-20 to 100	290	750	1500	2250	3750	6250	290	750	1500	2250	3750	6250
200	260	750	1500	2250	3750	6250	290	750	1500	2250	3750	6250
300	230	730	1455	2185	3640	6070	290	750	1500	2250	3750	6250
400	200	705	1410	2115	3530	5880	290	750	1500	2250	3750	6250
500	170	665	1330	1995	3325	5540	290	750	1500	2250	3750	6250
600	140	605	1210	1815	3025	5040	290	750	1500	2250	3750	6250
650	125	590	1175	1765	2940	4905	290	750	1500	2250	3750	6250
700	110	570	1135	1705	2840	4730	280	735	1465	2200	3665	6110
750	95	530	1065	1595	2660	4430	280	730	1460	2185	3645	6070
800	80	510	1015	1525	2540	4230	275	720	1440	2160	3600	6000
850	65	485	975	1460	2435	4060	260	680	1355	2030	3385	5646
900	50	450	900	1350	2245	3745	230	600	1200	1800	3000	5000
950	35	375	755	1130	1885	3145	180	470	945	1415	2355	3930
1000	20	255	505	760	1270	2115	120	315	635	950	1585	2645
1050	20(a)	170	345	515	855	1430	80	215	430	645	1070	1785
1100	20(a)	115	225	340	565	945	55	140	285	425	705	1180
1150	20(a)	75	150	225	375	630	35	95	190	285	470	785
1200	20(a)	50	105	155	255	430	25	65	130	195	320	535

NOTE: Use normalized and tempered material only. The deliberate addition of any element not listed in ASTM A217, Table 1 is prohibited, except that Ca and Mg may be added for deoxidation.

(a) Flanged end valve ratings terminate at 1000°F (537°C).

\* "Special Class" applies to weld-end valves only and requires NDE testing in accordance with ASME B16.34 - 2013.



# How To Order

## First 11 Figure Number Characters\*

Size		Type	Class	Material	Trim	Operator	End	Schedule	Weld End Prep	Mounting
1	2	A	1	A	8	H	F	4	B	0

\*The remaining 6 characters are used for Options, Features, Special Material Processes and Special Requirements. N is used to signify "No" requirement.

### Figure Number Rules for Size, Type and Class (first 4 characters)

SIZE		TYPE		CLASS	
02	2"	A	GATE (Flex-Wedge)	1	150#
2H	2.5"	B	GLOBE (T-Globe)	3	300#
03	3"	C	CHECK (Swing type)	6	600#
04	4"				
-	-				
18	18"				
20	20"				
24	24"				

### Figure Number Rules for Material (5<sup>th</sup> character)

MATERIAL		
No.	ASTM	Material
A	A216 WCB	Carbon Steel
B	A352 LCB	Low Carbon Steel
C	A352 LCC	Low Carbon Steel
D	A216 WCC	Carbon Steel
E	A217 WC6	11/4 CR, 1/2 Mo
F	A217 WC9	21/4 CR, 1 Mo
G	A217 C5	5% CR, 1/2 Mo
H	A217 C12	9% CR, 1 Mo
J	A351 CF8M	316 SS
L	A351 CF8	304 SS
M	A351 CF3	304L SS
N	A351 CF3M	316L SS
P	A351 CG8M	317 SS
Q	A351 CG3M	317L SS
R	A351 CF8C	347 SS
W	CD3MN	Duplex 1B
X	CD3MWCuN	Duplex 4A
Y	CD4MCuN	Duplex 6A
S	A351 CN7M	Alloy 20
Z		Special

### Figure Number Rules for Trim Material (6<sup>th</sup> character)

TRIM MATERIAL				
No.	API Trim No.	Nominal Trim	Seating Surfaces	Stem Material
	1	Obsolete (Offer Trim 8)		
5	5	HF / HF <sup>(2)</sup>	Alloy 6	13 Cr (410)
9	9	Monel® / Monel® <sup>(4)</sup>	Monel®	Monel®
8	8*	F6 / HF <sup>(1)(2)</sup>	13 Cr / Alloy 6	13 Cr (410)
1	11	Monel® / HF <sup>(4)(2)</sup>	Monel® / Alloy 6	Monel®
2	12	316 / HF <sup>(3)(2)</sup>	316SS / Alloy 6	316 SS
6	16	316/HF / 316/HF <sup>(3)(2)</sup>	316SS / Alloy 6 (both)	316 SS
E		8 to NACE MR0103 / MR0175		
N		12 to NACE MR0103 / MR0175		
Z		Special / Custom		

(1) 13% Chromium AISI Type 410 Stainless Steel.  
(2) Hard Facing is weld deposited Cobalt base alloy  
(3) Ni-Cr-Mo stainless steel in the AISI Type 316 category  
(4) Ni-Cu Alloy Standard Offering

### Figure Number Rules for Operator, Valve Ends, Schedule and Weld End Prep (7<sup>th</sup>, 8<sup>th</sup>, 9<sup>th</sup> & 10<sup>th</sup> characters)

OPERATOR		SCHEDULE	
0	N/A (e.g. check valves)	0 = N/A (e.g. flanged end)	F = Schedule 60
H	Handwheel	D = Schedule STD	G = Schedule 80 <sup>(2)</sup>
G	Bevel Gear	A = Schedule 10	H = Schedule XS
S	Bare Stem	B = Schedule 10S	J = Schedule 100
P	Pneumatic Cylinder	C = Schedule 20	X = Different Inlet & Outlet
E	Electric Motor Customer Supplied	K = Schedule 30	Z = Custom
C	Electric Motor with Bevel Gear	E = Schedule 4 <sup>(1)</sup>	
Y	Hydraulic Actuator Special / Custom		
Z			

(1) same as Schedule STD for size 2" - 10"  
(2) same as Schedule XS for size 2" - 8"

WELD END PREP	
0	N/A (e.g. flanged end)
B	2B Or 3B Based on wall thickness
C	2C or 3C Based on wall thickness
Z	Custom

VALVE ENDS	
F	Raised Face
W	Butt Weld End

### Figure Number Rules for Mounting (11<sup>th</sup> character)

MOUNTING	
0 = N/A <sup>(1)</sup>	
1 = F10	A = FA10
2 = F12	B = FA12
3 = F14	C = FA14
4 = F16	D = FA16
5 = F25	E = FA25
6 = F30	F = FA30
7 = F35	G = FA35
8 = F40	H = FA40
Z = Other / Special	

(1) e.g. Handwheel / Check Valve

### SPECIAL REQUIREMENT (digit 17)

N = None	M = MSS SP-61 testing
2 = API 600 12 <sup>TH</sup> edition	Z = Other
C = CE/PED	



Crane ChemPharma & Energy  
 Crane Energy Headquarters  
 4526 Research Forest Drive, Suite 400  
 The Woodlands, Texas 77381 U.S.A  
 Phone: +1 936-271-6500  
 Fax +1 936-271-6510  
 www.cranecpe.com



PRODUCT SOLUTIONS INC.

3160 118 Avenue SE  
 Calgary, AB T2Z 3X1  
 TOLL FREE: 888 770 8899  
 MAIN: 403 295 3114  
 EMAIL: sales@ngc-ps.com  
 WEB: ngc-ps.com

Pacific Valves Customer Service  
 3201 Walnut Avenue  
 Signal Hill, CA 90755 U.S.A  
 Phone: +1 562-426-2531  
 Fax +1 562-595-9717

Crane Cast Steel Customer Service  
 2129 3rd Avenue, S.E.  
 Cullman, Alabama 35055 U.S.A  
 Phone: +1 256-775-3800  
 Fax: +1 256-775-3860

**brands you trust.**



COMPAC-NOZ®



DEPA®

ELRO®

DUO-CHEK®



NOZ-CHEK®



RESISTOFLEX®



Saunders®  
*the science inside*

STOCKHAM®



UNI-CHEK®

w.ta®

XOMOX®

Crane Co., and its subsidiaries cannot accept responsibility for possible errors in catalogues, brochures, other printed materials, and website information. Crane Co. reserves the right to alter its products without notice, including products already on order provided that such alteration can be made without changes being necessary in specifications already agreed. All trademarks in this material are property of the Crane Co. or its subsidiaries. The Crane and Crane brands logotype, in alphabetical order, (ALOYCO®, CENTER LINE®, COMPAC-NOZ®, CRANE®, DEPA®, DUO-CHEK®, ELRO®, FLOWSEAL®, JENKINS®, KROMBACH®, NOZ-CHEK®, PACIFIC VALVES®, RESISTOFLEX®, REVO®, SAUNDERS®, STOCKHAM®, TRIANGLE®, UNI-CHEK®, WTA®, and XOMOX®) are registered trademarks of Crane Co. All rights reserved.