

# 45° Laterals, PTFE-Lined

CS = Carbon Steel  
 DI = Ductile Iron  
 FAB = Fabricated Steel  
 ATL = Advanced Technology Liner

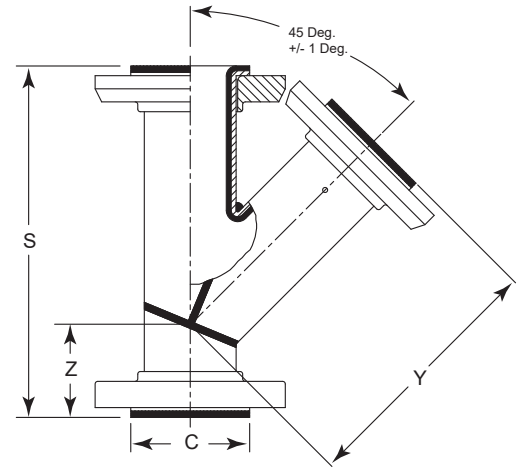

ASME B16.5 Class 150 Flanged														
Size (NPS)	Size (DN)	Dimensions								Available Construction			Weight	
		Y		Z		S		C		FAB with DI Rotating Flanges	FAB with CS Flanges (Fixed or Rotating)	ATL		
		Inch	mm	Inch	mm	Inch	mm	Inch	mm				lbs.	kg
1	25	5 3/4	146	1 3/4	44	7 1/2	191	2	51	●	●	●	11.4	5.2
1 1/2	40	7	178	2	51	9	229	2 7/8	73	●	●	●	17.7	8
2	50	8	203	2 1/2	64	10 1/2	267	3 5/8	92	●	●	●	25	11.4
3	80	10	254	3	76	13	330	5	127	●	●	●	52.8	24
4	100	12	305	3	76	15	381	6 3/16	157	●	●	●	96.8	44
6	150	14 1/2	368	3 1/2	89	18	457	8 1/2	216	●	●	●	145	65.9
8	200	17 1/2	445	4 1/2	114	22	559	10 5/8	270	●	●	●	219	99.5

Laterals are rated full vacuum to 450 °F.  
 Also available in stainless steel  
 Weights are approximate