

Ring Style Spectacle Blind

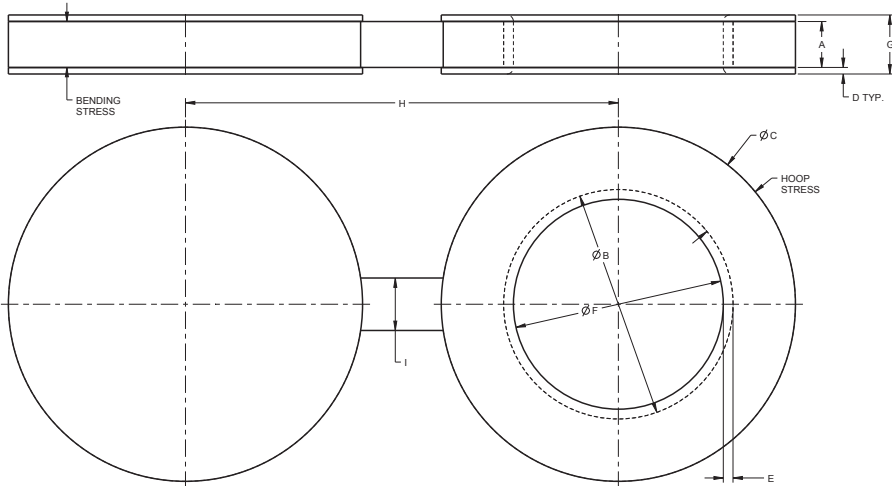

| DIMENSION | A | B | C | D | E | F | G | H | I |
|-------------------------|---------------|----------|----------|----------------------|----------------------|-------------------|------------------------|------------------|---------------|
| NOMINAL PIPE SIZE (NPS) | HUB THICKNESS | HUB I.D. | HUB O.D. | LINER FACE THICKNESS | LINER BORE THICKNESS | HUB I.D. W/ LINER | HUB THICKNESS W/ LINER | SPEC. BLIND CtoC | RIB THICKNESS |
| 1 | 0.625 | 1.375 | 2.5 | 0.125 | 0.188 | 1 | 0.875 | 4.5 | 1 |
| 1.5 | 0.625 | 1.875 | 3.25 | 0.125 | 0.188 | 1.5 | 0.875 | 5.25 | 1 |
| 2 | 0.625 | 2.375 | 4 | 0.125 | 0.188 | 2 | 0.875 | 6.25 | 1 |
| 3 | 0.875 | 3.375 | 5.25 | 0.125 | 0.188 | 3 | 1.125 | 7.75 | 1 |
| 4 | 0.875 | 4.375 | 6.75 | 0.125 | 0.188 | 4 | 1.125 | 9.25 | 1 |
| 6 | 0.875 | 6.375 | 8.625 | 0.125 | 0.188 | 6 | 1.125 | 11.25 | 1 |
| 8 | 1 | 8.375 | 10.875 | 0.125 | 0.188 | 8 | 1.25 | 13.75 | 1 |
| 10 | 1 | 10.5 | 13.25 | 0.188 | 0.25 | 10 | 1.375 | 16.25 | 1 |
| 12 | 1 | 12.5 | 16 | 0.188 | 0.25 | 12 | 1.375 | 19.25 | 1.5 |

