



# DRAIN-GARD® SAFETY SHIELDS

## RECAPTURE SPRAYOUTS

### OF HAZARDOUS LIQUID CHEMICALS



PRODUCT SOLUTIONS™

110, 3160 118 Avenue SE  
 Calgary, AB T2Z 3X1  
 TOLL FREE: 888 770 8899  
 MAIN: 403 295 3114  
 EMAIL: ngcsales@ngc-ps.com  
 WEB: ngc-ps.com

#### A DRAIN-GARD® SHIELD IS USEFUL

- For flanges, valves and special pipe connections
- Prevents sprayouts from contaminating the workplace
- Allows recapture of chemicals or corrosives
- Directs spillage to recovery containers
- A "must" where secondary containment is necessary
- Ideal on piping located directly over walkways
- Perfect for piping systems used for unloading barges, tankers and trailers to prevent spills into waterways

#### A DRAIN-GARD® SHIELD IS AN ASSET

- Satisfies federal and state regulations for secondary containment of hazardous or toxic liquid chemicals
- Simplifies recordkeeping and tracking of chemical spills and recovery
- Assures safety in critical piping systems

#### A DRAIN-GARD® SHIELD IS SPECIALLY DESIGNED

- Overlapping slotted edges prevent lateral blowout
- Spacer rods create a flow space to dissipate pressure
- A threaded nipple accommodates hose/pipe connection for retrieval and secondary containment
- Produced in "304" or "316" stainless steel for all pipe sizes
- May be customized with an alarm to signal a leak alert
- Many customized versions available
- Is easily installed... Only a screwdriver is required

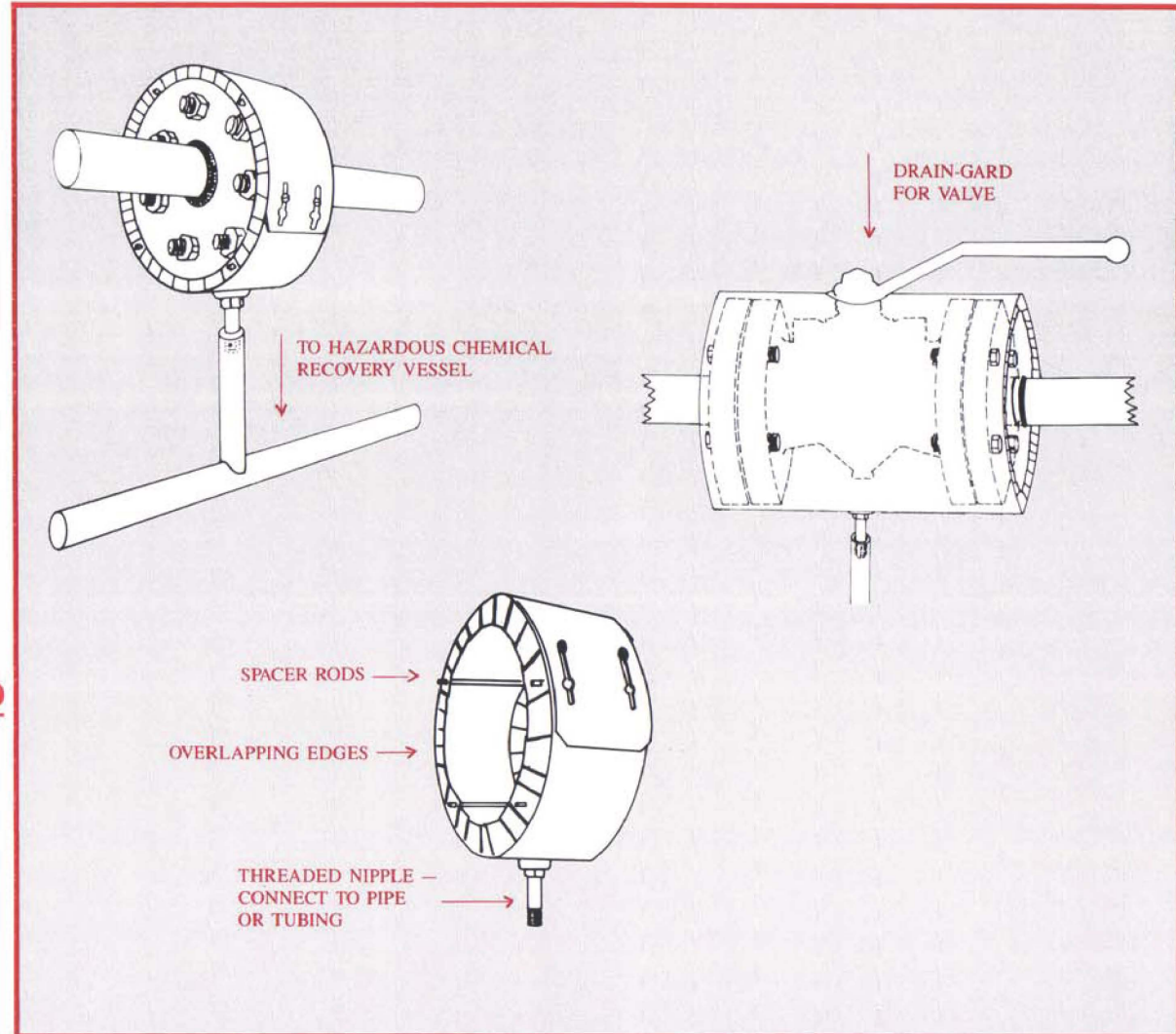

**ENSURE ENVIRONMENTAL SAFETY FOR PERSONNEL AND EQUIPMENT**

***"ONLY THE BEST IS ALWAYS SAFE"***

**RAMCO® MANUFACTURING CO., INC.**

365 Carnegie Avenue, Kenilworth, NJ 07033

Tel: 908-245-4500 • Fax: 908-245-3142 • Web Site: [www.ramco-safetyshields.com](http://www.ramco-safetyshields.com) • E-Mail: [info@ramco-safetyshields.com](mailto:info@ramco-safetyshields.com)

