

Multi-Axis® Bent Piping

- Available in 1" - 4" CS lined with PTFE, PP, and PVDF.
- 3 x diameter (3D) bend radius
- Up to 3 bends in 3 planes in a single piece of pipe.
- Sections are bent at any angle up to 90° with a tolerance of ±1°.
- Longer bend radius reduces pressure drop across the bend and reduces energy costs.
- 5D, 8D, 12D, and other bend radius available in PTFE-lined single bend.



The Bending Process

Although the concept behind MULTI-AXIS pipe is simple, successfully bending swaged plastic-lined pipe is not. It is considerably more difficult than bending unlined pipe. As for loose-lined pipe, it is virtually impossible to bend without distorting the liner. The liner in Resistoflex Plastic-Lined Pipe is locked into position and resists distortion.

Resistoflex uses special bending equipment and proprietary manufacturing techniques to provide bends in any angle up to 90° and compound bends on a single section of pipe. MULTI-AXIS pipe is a high-quality product with dimensional tolerances of ± 0.125" (3.2mm), even on pieces with multiple bends. Due to the complexity of the bending operation, field bending of MULTI-AXIS pipe is not available. MULTI-AXIS pipe can be supplied with Class 150 steel rotatable flanges or with plain ends that can be joined in the field with other plastic-lined pipe sections using CONQUEST® flangeless connections.

When considering MULTI-AXIS pipe, it's important to carefully examine directional changes in a system to determine whether the centerline-to-face or centerline-to-centerline dimensional requirements of bent pipe can be met within the parameters of the initial design. If not, design adjustments may be required.

Minimum Lengths Required for MULTI-AXIS Plastic Lined Pipe

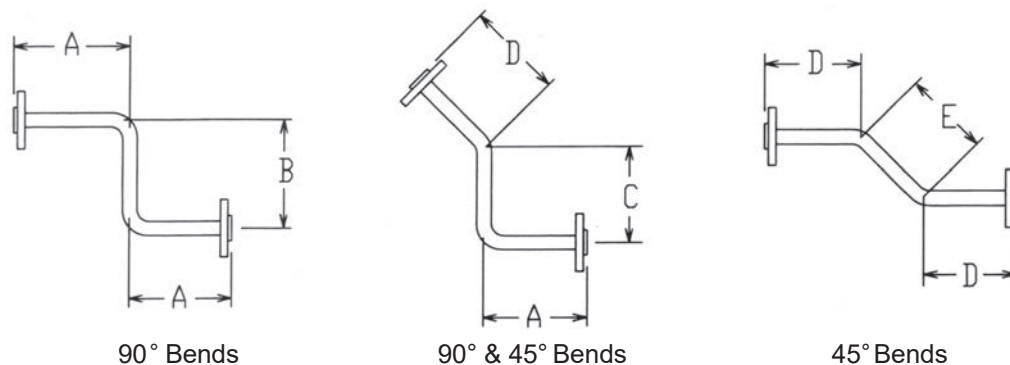

Coupler Dimensions					
Size NPS (DN)	A	B	C	D	E
1 (25)	6 1/8 (156)	11 3/8 (289)	8 1/2 (216)	4 1/4 (108)	6 3/4 (171)
1 1/2 (40)	9 3/16 (233)	15 3/16 (386)	12 1/2 (318)	6 7/16 (164)	9 3/4 (248)
2 (50)	11 1/4 (286)	18 1/4 (464)	14 5/8 (371)	8 (203)	10 3/4 (273)
3 (80)	15 (381)	26 11/16 (678)	22 (559)	10 (254)	15 3/4 (400)
4 (100)	19 3/4 (502)	36 1/2 (927)	29 1/2 (749)	12 7/8 (327)	22 1/4 (565)

Center-center and center-face dimensions = +/- 1/8" (3 mm)
 Bend angle = +/- 1°

1.5" and larger available as rotationally lined with Tefzel® ETFE. Consult factory for dimensional requirements.

Note: If there is a long run of straight pipe after the bend, this can result in the center of the next bend or the face of the flare being offset an inch or more from what was intended. In most cases, this can be compensated for in the field installation. In the case of bolting Multi-Axis to flanged equipment that is in a permanent fixed location, the offset may present an installation problem.