

**NGC**

PRODUCT SOLUTIONS LTD

3160 118 Avenue SE  
Calgary, AB T2Z 3X1  
TOLL FREE: 888 770 8899  
MAIN: 403 295 3114  
EMAIL: sales@ngc-ps.com  
WEB: ngc-ps.com



**GALLI & CASSINA**  
*Plus Valves.*  
**SINCE 1919**

# DOUBLE BLOCK & BLEED

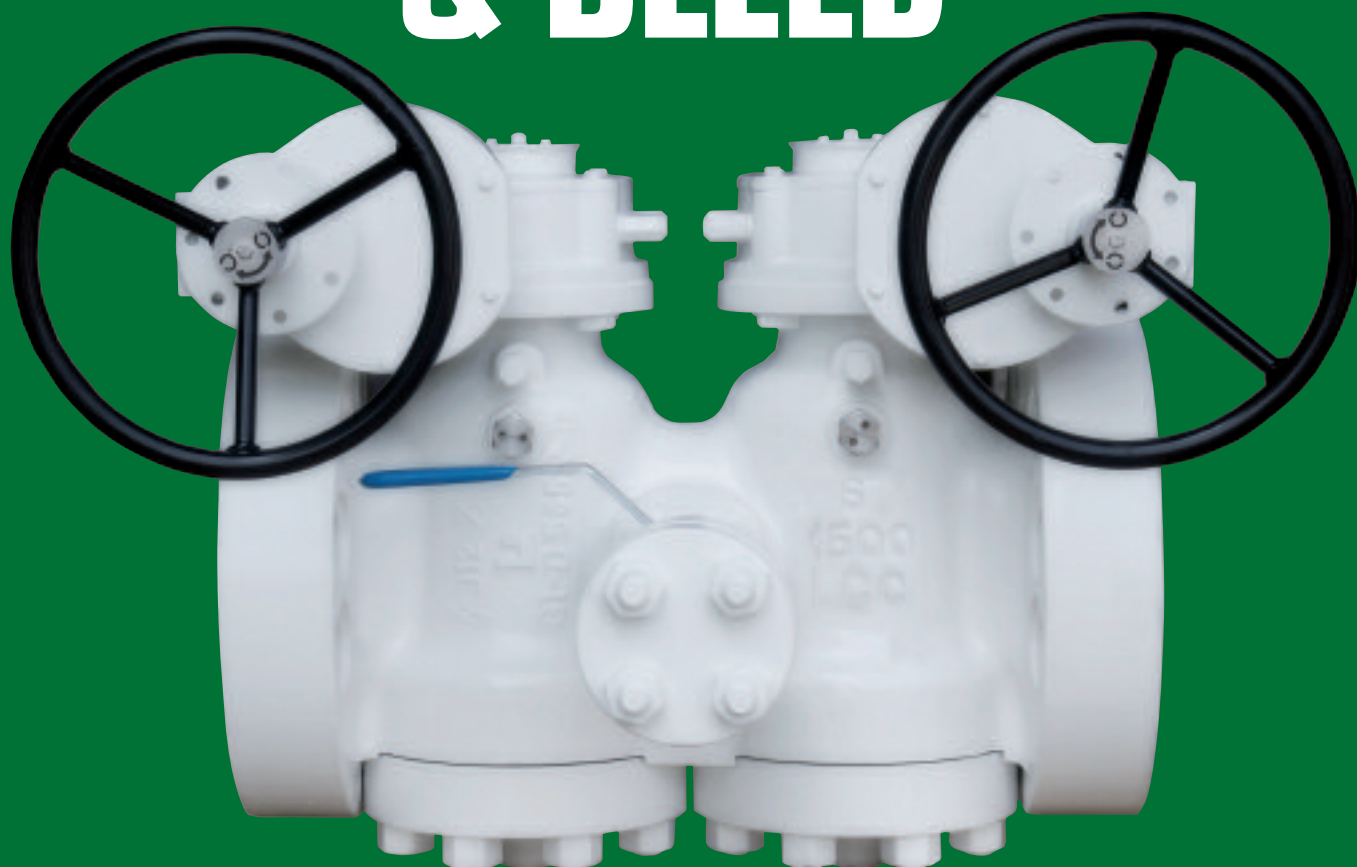

# PLUG VALVES

# Galli&Cassina Profile



Galli&Cassina is a prominent Italian Company mainly involved in the manufacture of a complete range of Lubricated Plug Valves.

The company is located in Solaro near Milan (Italy) with extensive offices and workshop covering

Galli&Cassina was established in 1919, and it is one of the oldest Italian companies still involved in the manufacturing of valves. At this early stage the business activity was concentrated in the production of valves for domestic and industrial purposes.

After the first ten

years the company gradually directed its production towards the newly born Chemical industry; it was the first in Italy to produce valves in stainless steel and other new material cooperating with the demand of the most important chemical Companies.

It was not possible to expand the Milan factory any more which was built in 1930 and enlarged after the second world war. For this reason in 1991 Galli&Cassina moved to a new factory in Solaro (Milan) with a very modern plant equipment, very comfortable for the workers.

After 30 years of experience in chemical valves, Galli&Cassina started the production of Plug Valves in the Oil & Gas business becoming one of the most significant suppliers for all International Gas & Oil Companies all over the world.

Its sales activity



a 12.000 sq.mt. area including 5.000 sq.mt. of covered space.







*covers most of the continents with a leading and growing presence in Europe, Middle East, North & South America and Far East resulting in a sales and service network with subsidiaries, branch offices and distributors, acquiring a reputation on high quality workmanship as well as on the reliability of its products.*

*Special care is due to the development in every aspect of the Company's management, complying with the continuous changes, requested by the evolution of the International markets.*

*The proved technical, productive,*

*and financial capabilities combined with the experience of human resources are the result of Galli&Cassina reputation all over the world.*



*Galli&Cassina's Quality Assurance System ISO 9001 - 2000 has been assessed, approved and certified by Lloyd's Register, while the API*



*6D and 6A monogram have been certified by API (American Petroleum*

*Institute) - Washington (U.S.A.).*

*Nowadays Galli&Cassina is proud to celebrate its 90 years, presence in the world of the valve market.*

*Galli&Cassina's historical background and experience allow the Company to offer strong professionalism and a comprehensive range service.*

*That will surely guarantee results in the future.*





# Index

Company Profile	2-3
Index	4

## Galli&Cassina Products

Product Identification System	6
Special Features Coating overlay	7
Material Selection Guide	8
Applicable Standard-Specification	9
Standard Features	10
Plug PTFE Antifriction Treatment	10
Special Features Coating & Overlay	10
ANSI Class 150 (PN 20)	11
ANSI Class 300 (PN 50)	12
ANSI Class 600 (PN 100)	13
ANSI Class 900 (PN 150)	14
ANSI Class 1500 (PN 250)	15
ANSI Class 2500 (PN 420)	16
API 6A-2000-3000-5000-10000	17
Hydraulic Pressure Test Duration and Pressure Test Tables in Accordance with API598 & API 6D	18
Quality Assurance Programme	19
Quality Assurance System	20

## Engineering Data

Lubricants	
Climax Hydraulic Gun N. 1699	21
Climax Lubricants	22
Fire Safe Test & Available test	23
Temperature Conversion Table	24
Pressure/Temperature Rating according to ASME B16.34-1996	25
Chemical and Mechanical Requirements Forged/ bar Materials for Body, Plug, Cover and Stem Components	26-27
Chemical and Mechanical Requirements Cast Materials for Body, Plug and Cover Components	28-29
Qualification of other Size Valves - API 6FA	30
Qualification of other Pressure Rating Valves	

*The data reported in this catalogue refer to the International Standards applicable at the time of its issue date. Galli&Cassina reserves the right to modify its products without any obligation to notify, provide or install such modification on products previously or subsequently sold. However Galli&Cassina will use the best effort to keep the customers informed of any changes made.*





# Double Block & Bleed Plug Valve

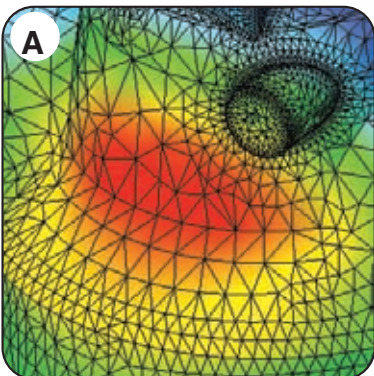
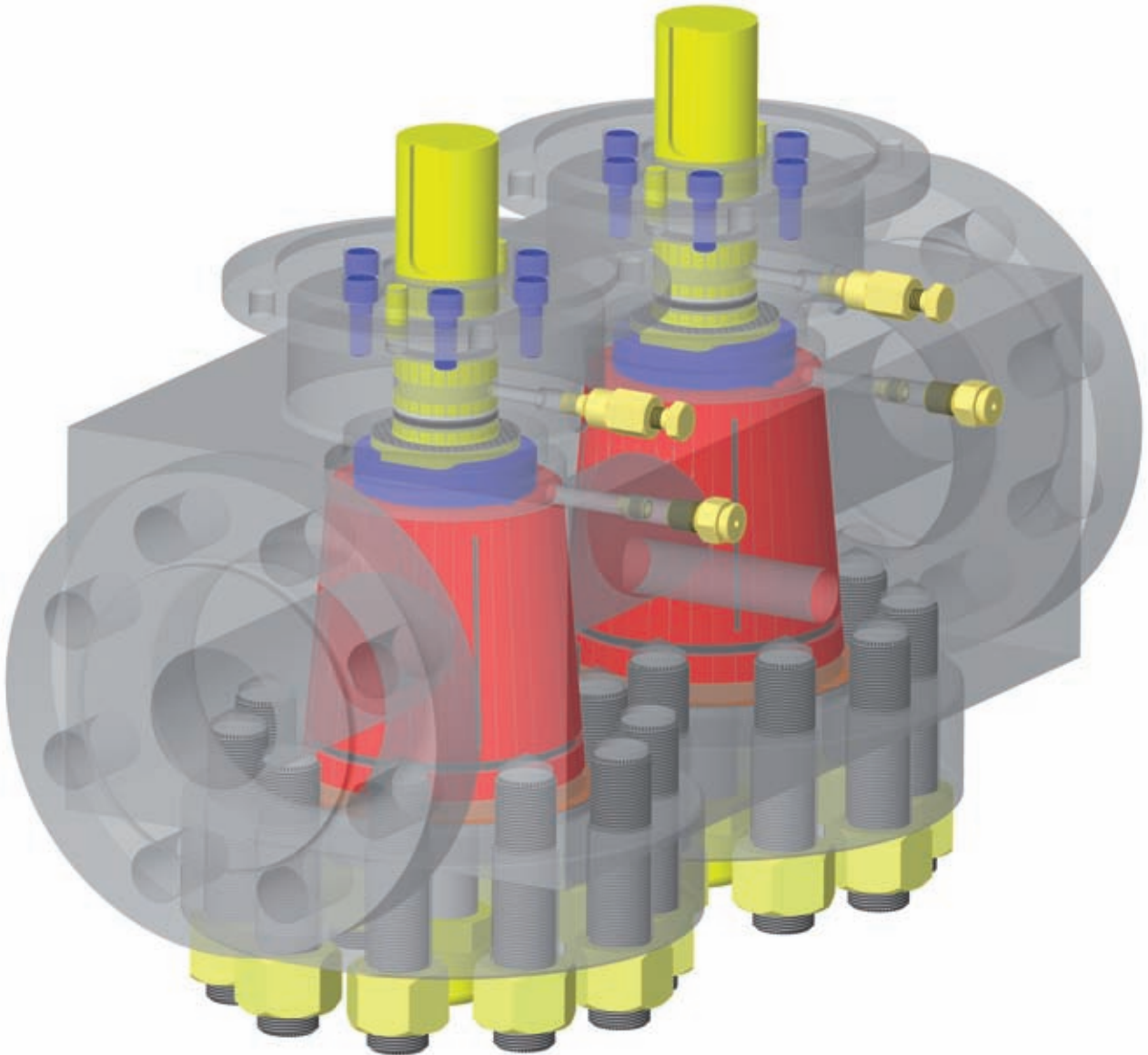

*Three - dimensional CAD system and the Finite Element Modelling allow the optimization of every step of valve's design:*

- FEM stress calculation of the pressure containing parts (**A**)
- Raw Casting design
- Final Assembly Design Check

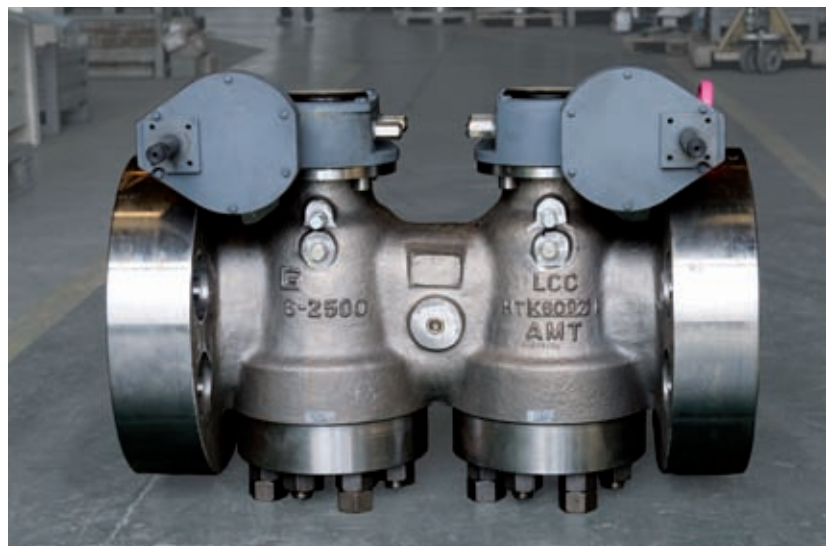



## Introduction

Galli & Cassina is proud to announce a NEW DOUBLE BLOCK & BLEED plug valve series. The addition of this API-6D compliant design is another major contribution Galli & Cassina's Plug valve line.

The Double Block and Bleed valves present similar features as the Galli & Cassina "Single Plug" series.

These are marketed with Reduced or Full bore, full conduit, pig-able design.

All plug valves are with Standard or Pressure balanced plugs. The Double Block and Bleed valve is developed to meet the industry demand for an alternate to other design where the service often develop problems with leakage in the seating areas. These problems are eliminated with the DBB valve as the plug valve does not have conventional seats as in gate or ball valves.

The DBB valve offers two plugs in one body, but maintain the face-to-face as per API-6D.

Therefore it is possible to replace other valves with API-6D f-f dimensions. An added feature is the substantially reduced weight compared to a conventional where three individual valves are installed to obtain the same feature.

Applications are mainly in the O & G sector where special features often are required, due to severe operating conditions.

According to API-6D these valves must warrant "Zero-leakage" at maximum differential across the valve.

The transportation of Hydrocarbon gasses or Crude Oil which may contain H<sub>2</sub>S, CO<sub>2</sub> or other contaminants often create serious corrosion problems in valves. For this reason Galli & Cassina offer a wide range of specialty materials in accordance with NACE or special customer requirements.

To resolve the industry problems with corrosion, erosion and abrasive services under severe operating conditions Galli & Cassina offer an extensive range of "hard face materials" as Stellite, Inconel and Tungsten Carbide and others as Duplex, 6Mo or Nickel alloy.

The hard facing is applied in the Galli & Cassina factory using own automatic welding robot's and under strict control of the R&D and QA Department. Galli & Cassina is a ISO 9001 approved facility and hold API-6A and API-6D (with monogram) approvals.

## Product Identification System

Identification numbers here shown are used to describe essential features of Galli&Cassina valves

### Example: 200 DRR06R0001

200	Size	<ul style="list-style-type: none"> <li>• 1" 025</li> <li>• 1 1/2 040</li> <li>• 2" 050</li> <li>• 3" 080</li> <li>• 4" 100</li> </ul>	<ul style="list-style-type: none"> <li>• 6" 150</li> <li>• 8" 200</li> <li>• 10" 250</li> <li>• 12" 300</li> <li>• 14" 350</li> </ul>	<ul style="list-style-type: none"> <li>• 16" 400</li> <li>• 18" 450</li> <li>• 20" 500</li> </ul>
D	Valve Type	• D Double Block & Bleed		
R	Pattern	<ul style="list-style-type: none"> <li>• R Reduce bore</li> <li>• F Full bore</li> </ul>		
R	Valve Operator Type	<ul style="list-style-type: none"> <li>• C Lever</li> <li>• R Gear</li> <li>• E Gear with Electric Motor</li> </ul>	<ul style="list-style-type: none"> <li>• A Actuator (Pneumatic or gas overoil)</li> <li>• B Bare Stem</li> </ul>	
06	Working Pressure Class	<b>API 6D Valves</b> <ul style="list-style-type: none"> <li>• 150 01</li> <li>• 400 04</li> <li>• 900 09</li> <li>• 2500 25</li> </ul>	<ul style="list-style-type: none"> <li>• 300 03</li> <li>• 600 06</li> <li>• 1500 15</li> </ul>	<b>API 6A Valves</b> <ul style="list-style-type: none"> <li>• 2000 20</li> <li>• 5000 50</li> <li>• 15000 1K</li> </ul>
R	Valve End Connections	<ul style="list-style-type: none"> <li>• R RF Flange</li> <li>• W Butt Weld</li> <li>• B Butt Weld by flange</li> </ul>	<ul style="list-style-type: none"> <li>• J Ring Joint Flange</li> <li>• C Clamp</li> <li>• N Pups</li> </ul>	
0001	Internal Material Identification (TRIM)	• According to client's materials requirement		

The Code used as sample above (200 DRR06R 0001) identifies a: DN 200 (8") - Double Block & Bleed Valve - Reduce bore - Gear Operator - ANSI 600 - Flanged RF ends connections - Standard carbon steel materials, suitable for ambient and high temperature service.





## Standard Features: the Pressure Balance System

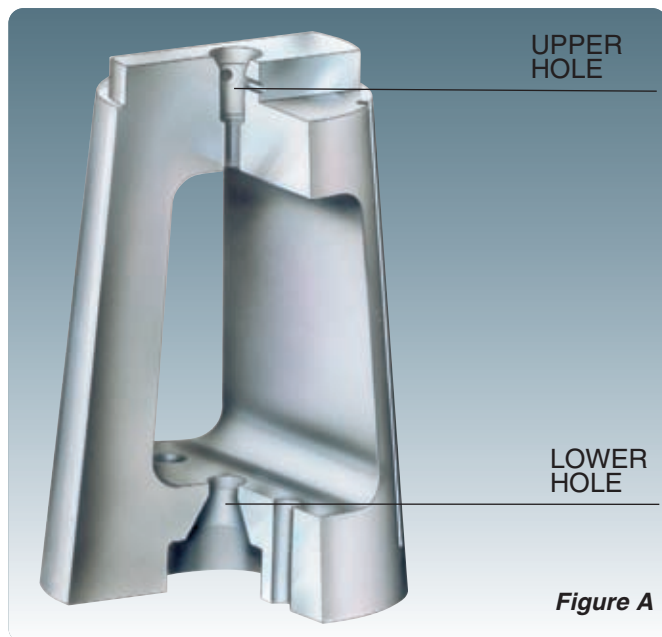

Figure A

The operating system of Pressure Balanced Plug Valves (shown in Fig.A) consist in the pressure equalization between the port area and the top/bottom of the plug with two holes.

The upper hole connects the plug port area with the top of the plug, while the lower maintains the pressure equalization between the port area and the bottom of the plug. The Pressure Balance System ensure line pressure acts on the plug to reduce the valve torque and avoid the possibility of plug seizure, even after a prolonged time in the open or closed position.

The tapered shape of the

plug guarantees that the force created by line pressure pushes the plug against the body seat. As differential pressure increase so does the sealing capability of the Pressure Balanced Plug Valve. Thanks to pressure balance feature, and to the integral metal to metal design, Plug Valve can always be opened against the maximum delta pi. No by-pass is necessary to preserve seat integrity. Periodic lubricant injection, and seat adjustment can be carried out when the Plug Valve is under full pressure. Only severe seat damage will cause a reduction of valve sealing.

## Special Features: Coating & Overlay

### Hardfacing

Galli & Cassina's researching, development and investment in hardfacing materials against corrosion or abrasion attack, in cooperation with specialized companies and external laboratories, have given the right

experience to apply in own workshop by automatic welding robot machines all kind of overlay (Stellite, Inconel, Duplex, 6MO, Nickel alloy and Tungsten Carbide) on each component of the valve directly. These performance are especially highlighted in case of severe operating

conditions. Moreover, higher hardness values greater than 1100 HV/70 HRC) compared to standard hardfacing (Stellite 6, with 37-40 HRC hardness) provide a very good abrasion & wear resistance. All the overlay applications are controlled by NDE test, such as LP UT PMI and

thickness check, witnessed by G&C Quality Control inspectors or customer's inspectors upon request. The improvement of the welding quality can guarantee an high performance of G&C plug valves in Off-Shore/On-Shore Petrochemical and Drilling applications.

### Electroless Nickel Plating

The transport of wet hydrocarbon gases contaminated with hydrogen sulphide, carbon dioxide or other similar fluids containing appreciable level of sulphur, can create various corrosion problems to some component in plug valves.

These environments are not always recognized under service conditions, therefore in order to obtain a high quality corrosion



resistant, all the material for each component of the valves, are selected in accordance with the requirements of NACE-Std. MR-01-75 Latest Edition. Moreover the use of an electroless nickel plating on plug surface provides more corrosion protection to hydrogen sulphide crack-resistant base metal. Standard ENP is in accordance with ASTM B733 Std with a minimum 0.003" (76 Microns) thickness, unless otherwise specified in the customer's specification.

### Tungsten Carbide Coating

A series of metal carbide coatings (WC+Ni, Cr or

WC+Co or WC+Co, Cr), usually known as Tungsten Carbide (TCC) allows to achieve higher performance in terms of valve working life.

These performances are specially highlighted in case of severe operating conditions. Moreover, higher hardness values (greater

than 1100 HV / 70 HRC) compared to standard hardfacing (Stellite 6, 37 - 40 HRC) provide a very good abrasion & wear resistance.



# Material Selection Guide for GALLI & CASSINA Valves

Trim materials are designed according to the service conditions.

- 1 Standard Carbon Steel Body and Plug. (ASTM-A216 WCB/WCC material) suitable for general services.
- 2 Carbon Steel Body and Plug (A352 LCB/LCC material) suitable for low temperature services.
- 3 Carbon Steel Body and Plug (ASTM A216WCB/WCC material) suitable for "SOUR SERVICE"(H<sub>2</sub>S and CO<sub>2</sub>) according to NACE-MR.01.75/Latest Edition.
- 4 Special Austenitic (6MO) and Ferritic-Austenitic Stainless Steel (Duplex and Superduplex) suitable for sea water and corrosive services.
- 5 Nickel-Chromium-Iron alloy (i.e. Alloy 20), Titanium & Titanium alloy, carbon steel with Inconel 625 cladding and stellite or Tungsten carbide hardfacing for abrasive/corrosive service.
- 6 Other materials upon request.

## Standard Design Categories (Typical Construction Materials)

Trim Service	Class	Body/Cover	Plug	Stem and Oldham Coupler	Bolting		
1 Standard service Natural gas Hydrocarbons	150 to 2500	ASTM A105	ASTM A105	ASTM A29 Gr. 4140	ASTM A193-B7M ASTM A194-2HM		
		ASTM A216	ASTM A216				
		WCB/WCC	WCB/WCC				
		Max C 0.25%					
2 Low temperature Natural gas Hydrocarbons	150 to 2500	ASTM A350-LF2	ASTM A350-LF2	ASTM A29 Gr. 4140	ASTM A320-L7 ASTM A194 Gr.7		
		ASTM A352 LCB/LCC	ASTM A352- LCB/LCC				
3 Sour Service (H <sub>2</sub> S and CO <sub>2</sub> ) Hydrocarbons	150 to 2500	ASTM A105	ASTM A105	ASTM A29 Gr. 4140 Max HRC22	ASTM A193-B7M ASTM A194-2HM MAX HRC22		
		ASTM A216 WCB/WCC	ASTM A216 WCB/WCC				
4 Sea Water	150 to 2500	UNS S31254	UNS S31254	UNS S31254	ASTM A453 Gr.660A		
		ASTM A 351 CK3MCuN (6MO)					
		UNS S31803	UNS S31803			UNS S31803	ASTM A453 Gr.660A UNS S32760
		ASTM A 890 J92205 (Duplex 22% Cr)					
5 Abrasive/Corrosive Slurry service	150 to 2500	UNS S32750	UNS S32750	UNS S32750	UNS S32760		
		ASTM A 890 J93404 (Super duplex 25% Cr)					
		UNS S32760	UNS S32760			UNS S32760	UNS S32760
		ASTM A 890 J93380 (Super duplex 25% Cr)					
5 Abrasive/Corrosive Slurry service	150 to 2500	ASTM B348 Gr 3 or 5 (Titanium)	ASTM B348 GR 3 or 5	UNS S31254 UNS S32760	ASTM A453 Gr.660A		
		UNS N08020	UNS N08020			UNS S32750	ASTM A453 Gr.660A
		ASTM A 351 CN7M (Alloy 20)	ASTM A 351 CN7M			UNS S32760	UNS S32760
5 Abrasive/Corrosive Slurry service	150 to 2500	ASTM A 105		ASTM A 29 Gr 4140	ASTM A193 B7M ASTM A194 2HM		
		ASTM A 216 WCB/WCC Hardfacing (Stellite/WC) and Cladding (Inconel 625)					





## Applicable Standard-Specification

**Lubricated Plug Valves are designed to use with most refining services according to API 599 or BS 5353 norms whichever is applicable. API 6D norm aims to standardize the materials as well as instructions to manufacture valves suitable for energy transportation in the pipelines.**

API 6A	Specification for wellhead and christmas tree equipment.	BS 1504	Specification for Steel Casting for Pressure Purposes.
API 6D	Specification for Pipeline Valves.	BS 2080	Face to Face - Centre to Face - End to End - Steel Valves.
API 6FA	Specification for Fire Test for Valves.	BS 5353	Specification for Steel Plug Valves.
API RP6F	Recommended - Practice for Fire Test for Valves.	BS 6755 part 1	Testing of Valves (Spec. for Production Pressure Testing Requirements).
API 598	Valve Inspection and Testing.	BS 6755 part 2	Testing of valves (Spec. for Fire Safe Testing Requirements).
API 599	Steel Plug Valves Flanged or Butt Welding Ends.		
ASME/ANSI B 16.5	Pipe Flanges and Flanged Fittings.	CSA Z 245. 15	Canadian Standard Association.
ASME/ANSI B 16.10	Face-to-Face and End-to-End Dimensions of Valves.	MSS-SP6	Standard Finish for contact Face of Pipe Flanges.
ASME/ANSI B 16.25	Buttwelding Ends.	MSS-SP25	Standard Marking System for Valves.
ASME/ANSI B 16.34	Valves-Flanged, threaded and Welding Ends.	MSS-SP44	Steel Pipe Line Flanges.
ASME/ANSI B 31.3	Chemical Plant and Petroleum Refinery Piping.	MSS-SP53	Quality Standard for Steel Casting-Magnetic Particle Examination Method.
ASME/ANSI B 31.4	Liquid Transportation System for Liquid Petroleum Gas.	MSS-SP54	Quality Standard for Steel Casting-Radiographic Examination Method.
ASME/ANSI B 31.8	Gas Transmission and Distribution Piping System.	MSS-SP55	Quality Standard for Steel Casting Visual Method.
ASME	Boiler and Pressure Vessel SECTION VIII - DIV.1 & 2	MSS-SP61	Pressure Testing of Steel Valves.
ASME	Boiler and Pressure Vessel Section V.		
ASNT-TC-1A	Recommended Practice for Personnel Qualification and Certification in Non destructive Testing.	NACE Std. MR 01.75 Latest Edition	National Association of Corrosion Engineers.
		ASTM	American Society for Testing and Materials.



## Standard Features: Plug PTFE Antifriction Treatment

Carbon Steel plugs are subjected to the following treatments:

- A) Case hardening.
  - B) Antifriction treatment.
- The case hardening has the purpose to increase

only the hardness of the plug surface which is subjected to wearing, keeping at the same time the mechanical properties of the base material unchanged.

Consequently the base material has more toughness and resistance against impacts. The Antifriction treatment is basically carried out on the plug

- to obtain the following advantages:
- Low friction between plug and body.
  - Low torque.
  - Wear resistance.
  - Resistance to seizure.



Plug with PTFE Antifriction treatment.



Plug without PTFE Antifriction treatment.



Plug with PTFE Antifriction treatment.



Plug without PTFE Antifriction treatment.

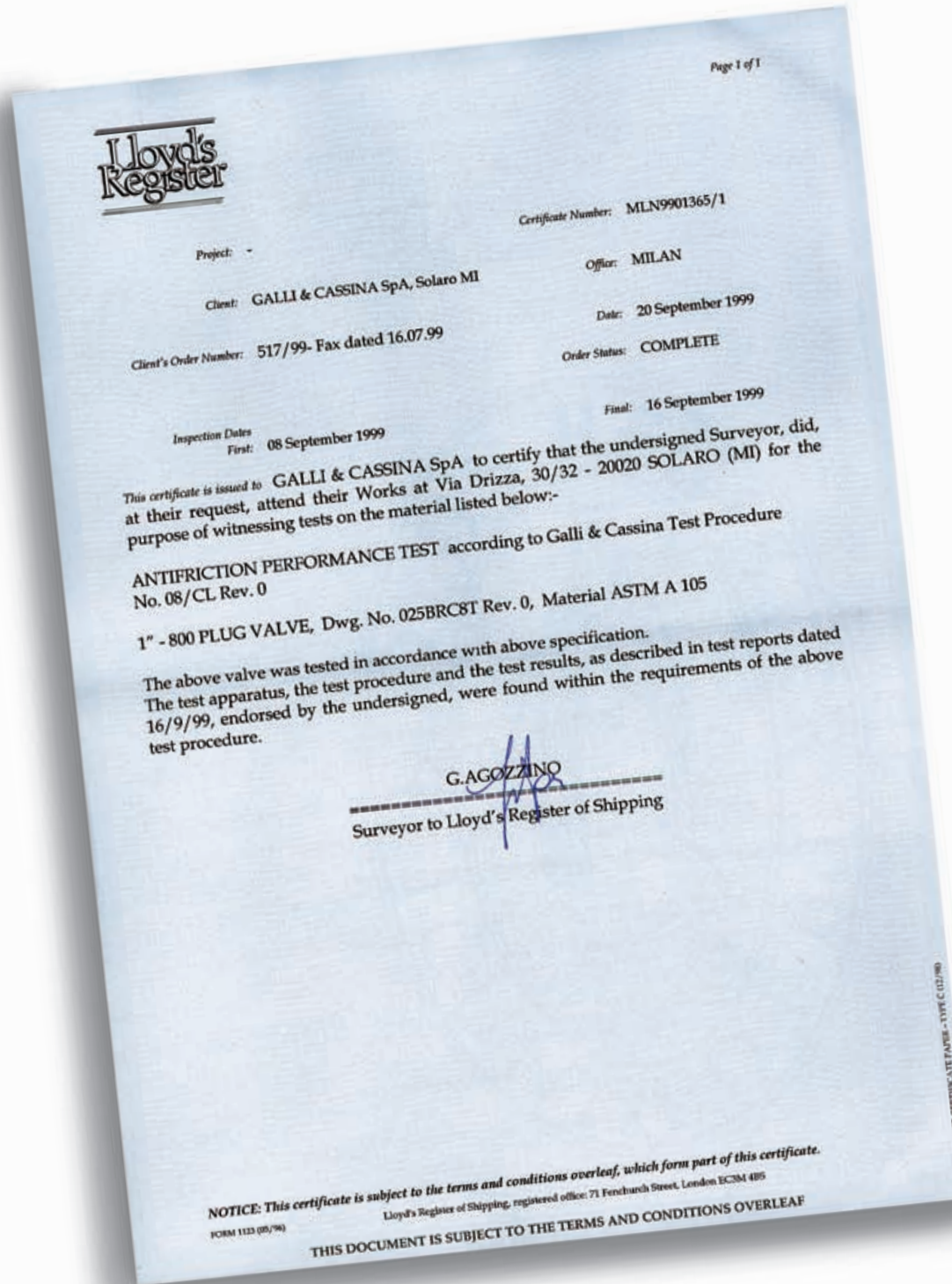

▲ The purpose of the above test is to prove that Galli&Cassina antifriction treatment made on plug surface, is guaranteed even after 30,000 cycles (open/closed position).





# ANSI Class 150 (PN 20)

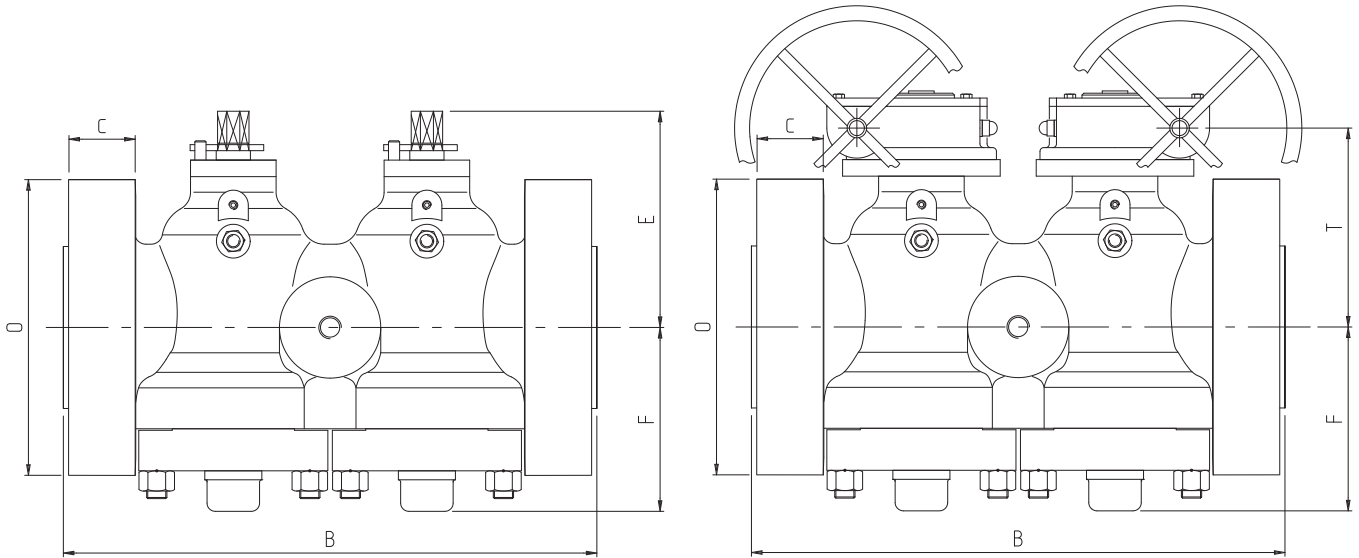

Size	NPS DN	2 50	3 80	4 100	6 150	8 200	10 250	12 300	14 350	16 400	18 450	20 500
<b>Face To Face</b>												
RF	<b>B</b>	267	343	432	546	622	661	762	889	991	1092	1194
RTJ	<b>B</b>	279	355	445	558	635	674	774	902	1004	1104	1209
Flange Diameter	<b>O</b>	152	191	229	279	343	406	483	533	597	635	699
Flange Thickness	<b>C</b>	16	19	24	26	29	30	32	35	37	40	43
Top of Stem to Center Line	<b>E</b>	180	220	240	250	-	-	-	-	-	-	-
Body Cap to Center Line	<b>F</b>	120	165	180	210	270	320	365	380	400	420	470
Center Line Valve to CL Operator	<b>T</b>	-	-	-	280	320	370	420	420	420	450	500
Handwheel Diameter	<b>G</b>	-	-	-	560	560	560	560	500	700	700	700
Length of Wrench	<b>L</b>	450	500	750	-	-	-	-	-	-	-	-
Size of Bleed Connection MSS SP 45		1/2"	1/2"	1/2"	1/2"	3/4"	3/4"	3/4"	1"	1"	1"	1"

Other size upon request



# ANSI Class 300 (PN 50)

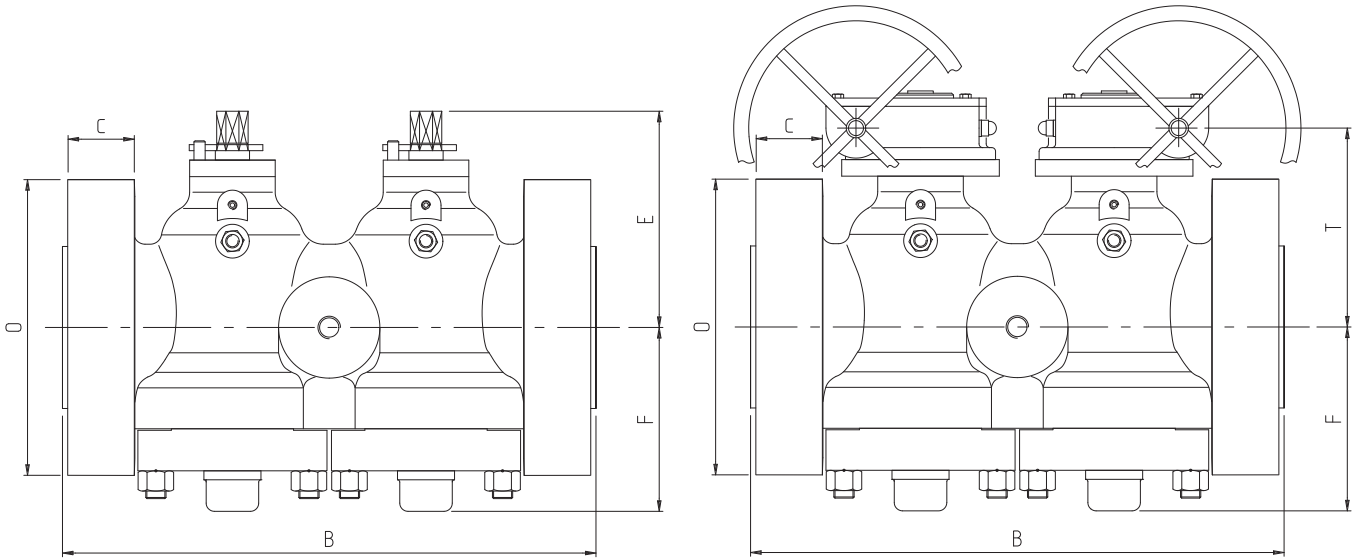

Size	NPS DN	2 50	3 80	4 100	6 150	8 200	10 250	12 300	14 350	16 400	18 450	20 500
<b>Face To Face</b>								*	*	*	*	*
RF	<b>B</b>	283	387	457	559	686	826	864	889	991	1092	1194
RTJ	<b>B</b>	298	403	473	575	702	841	881	905	1006	1108	1213
Flange Diameter	<b>O</b>	165	210	254	318	381	445	521	584	648	711	775
Flange Thickness	<b>C</b>	22	29	32	37	42	48	51	54	58	61	64
Top of Stem to Center Line	<b>E</b>	180	220	240	-	-	-	-	-	-	-	-
Body Cap to Center Line	<b>F</b>	120	165	180	220	285	320	380	400	430	460	510
Center Line Valve to CL Operator	<b>T</b>	-	-	-	-	330	370	430	445	450	490	540
Handwheel Diameter	<b>G</b>	-	-	-	560	560	560	700	700	700	700	800
Length of Wrench	<b>L</b>	500	750	750	-	-	-	-	-	-	-	-
Size of Bleed Connection MSS SP 45		1/2"	1/2"	1/2"	1/2"	3/4"	3/4"	3/4"	1"	1"	1"	1"

\* Face to face not in accordance with API 6D - ASME B16.10  
Other size upon request





# ANSI Class 600 (PN 100)

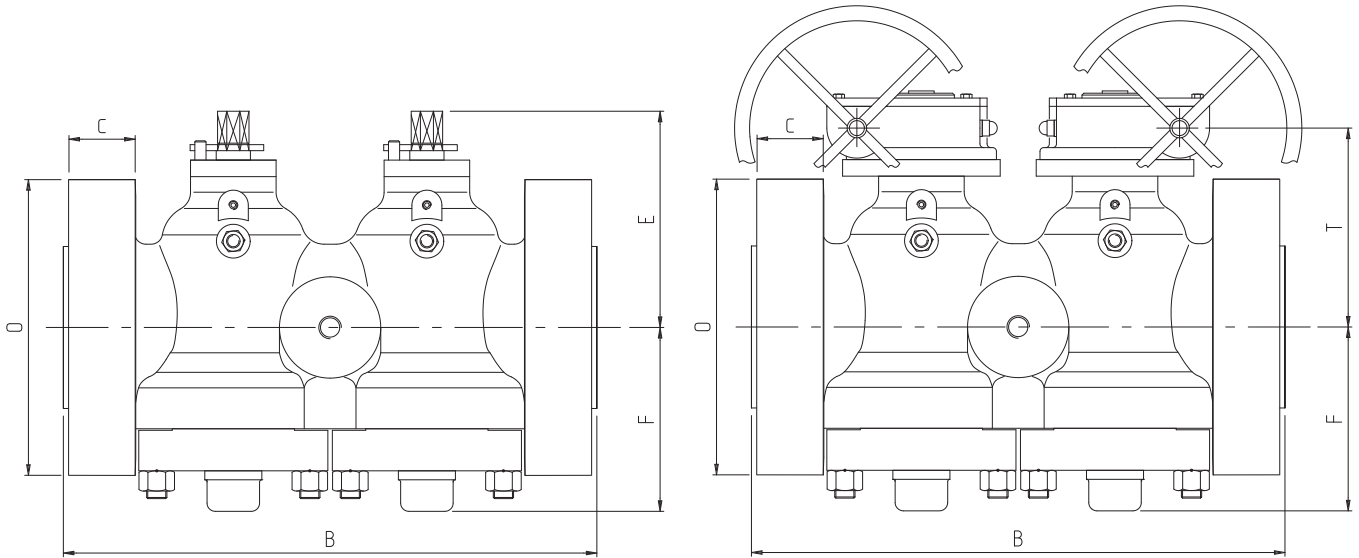

Size	NPS DN	2 50	3 80	4 100	6 150	8 200	10 250	12 300	14 350	16 400	18 450	20 500
<b>Face To Face</b>												
RF	<b>B</b>	292	356	432	559	660	787	838	889	991	1092	1194
RTJ	<b>B</b>	295	359	435	562	664	791	841	892	994	1095	1200
BW	<b>B</b>	292	356	432	559	660	787	838	889	991	1092	1194
Flange Diameter	<b>O</b>	165	210	273	356	419	508	559	603	686	743	813
Flange Thickness	<b>C</b>	26	32	38	48	56	64	67	70	77	83	89
Top of Stem to Center Line	<b>E</b>	180	220	240	-	-	-	-	-	-	-	-
Body Cap to Center Line	<b>F</b>	120	165	180	250	300	320	390	412	455	480	520
Center Line Valve to CL Operator	<b>T</b>	-	-	280	295	350	380	420	565	650	680	700
Handwheel Diameter	<b>G</b>	-	-	560	560	700	800	800	800	800	800	800
Length of Wrench	<b>L</b>	500	750	1000	-	-	-	-	-	-	-	-
Size of Bleed Connection MSS SP 45		1/2"	1/2"	1/2"	1/2"	3/4"	3/4"	3/4"	1"	1"	1"	1"

Other size upon request



# ANSI Class 900 (PN 150)

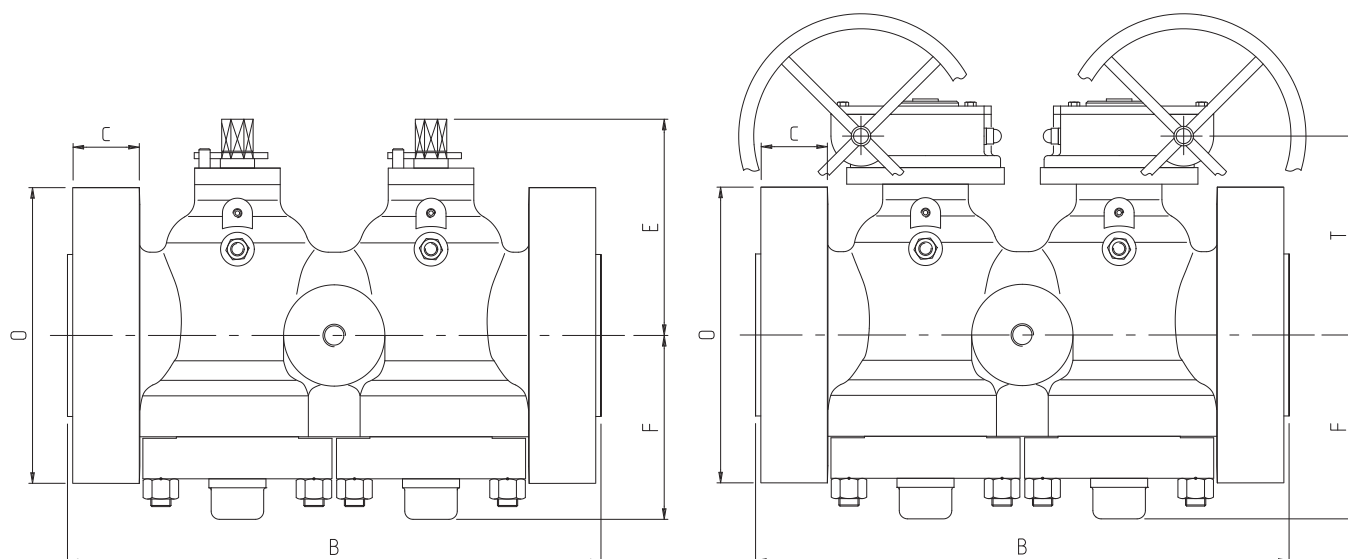

Size	NPS DN	2 50	3 80	4 100	6 150	8 200	10 250	12 300	14 350	16 400	18 450	20 500
<b>Face To Face</b>											*	
RF	<b>B</b>	368	381	457	610	737	838	965	1029	1130	1219	1321
RTJ	<b>B</b>	371	384	460	613	740	841	968	1038	1140	1232	1334
BW	<b>B</b>	368	381	457	610	737	838	965	1029	1130	1219	1321
Flange Diameter	<b>O</b>	216	242	292	381	470	546	610	642	705	787	857
Flange Thickness	<b>C</b>	38	38	45	56	64	70	80	86	89	102	108
Top of Stem to Center Line	<b>E</b>	180	220	-	-	-	-	-	-	-	-	-
Body Cap to Center Line	<b>F</b>	130	180	190	200	270	350	380	430	470	485	500
Center Line Valve to CL Operator	<b>T</b>	-	-	250	260	335	380	450	495	590	595	600
Handwheel Diameter	<b>G</b>	-	-	560	560	560	700	700	700	800	800	800
Length of Wrench	<b>L</b>	500	750	-	-	-	-	-	-	-	-	-
Size of Bleed Connection MSS SP 45		1/2"	1/2"	1/2"	1/2"	3/4"	3/4"	3/4"	1"	1"	1"	1"

\* Face to face not in accordance with API 6D - ASME B16.10  
Other size upon request





# ANSI Class 1500 (PN 250)

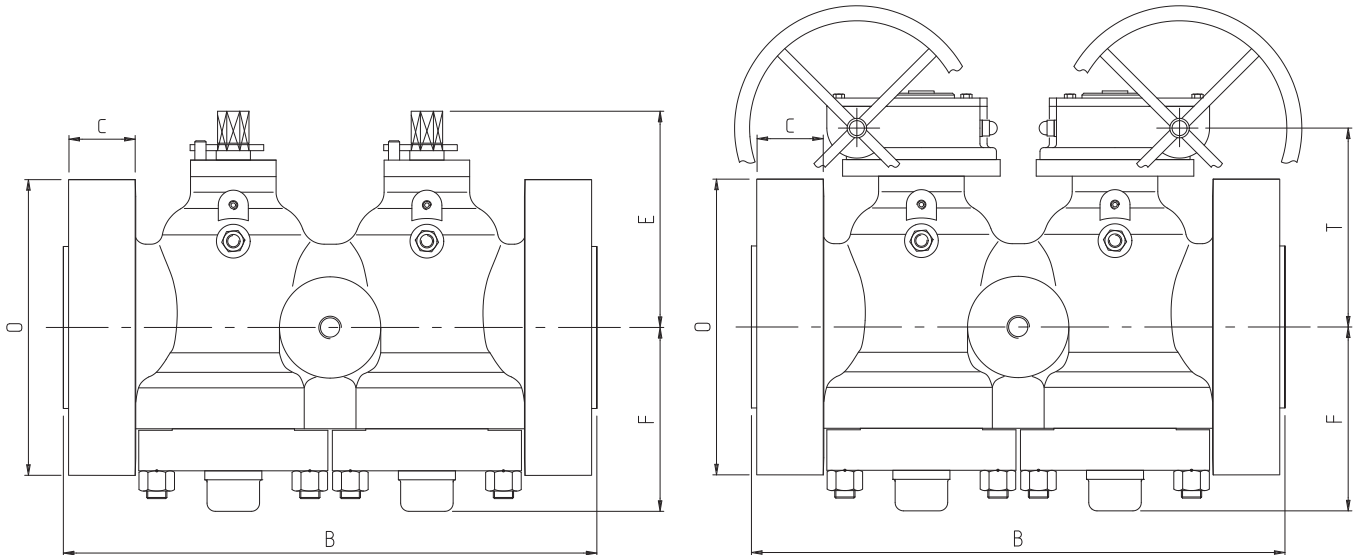

Size	NPS DN	2 50	3 80	4 100	6 150	8 200	10 250	12 300	14 350	16 400	18 450	20 500
<b>Face To Face</b>											*	
RF	<b>B</b>	368	470	546	705	832	991	1130	1257	1384	1537	1664
RTJ	<b>B</b>	371	473	549	711	841	1000	1146	1276	1406	1559	1686
BW	<b>B</b>	368	470	546	705	832	991	1130	1257	1384	1537	1664
Flange Diameter	<b>O</b>	216	267	311	394	483	584	673	749	825	914	984
Flange Thickness	<b>C</b>	38	48	54	83	92	108	124	133	146	162	178
Top of Stem to Center Line	<b>E</b>	210	235	-	-	-	-	-	-	-	-	-
Body Cap to Center Line	<b>F</b>	180	190	200	225	280	390	440	490	530	545	560
Center Line Valve to CL Operator	<b>T</b>	-	-	250	265	370	400	530	580	610	630	640
Handwheel Diameter	<b>G</b>	-	-	560	560	700	700	700	800	800	800	800
Length of Wrench	<b>L</b>	750	1000	-	-	-	-	-	-	-	-	-
Size of Bleed Connection MSS SP 45		1/2"	1/2"	1/2"	1/2"	3/4"	3/4"	3/4"	1"	1"	1"	1"

\* Face to face not in accordance with API 6D - ASME B16.10  
Other size upon request



# ANSI Class 2500 (PN 420)

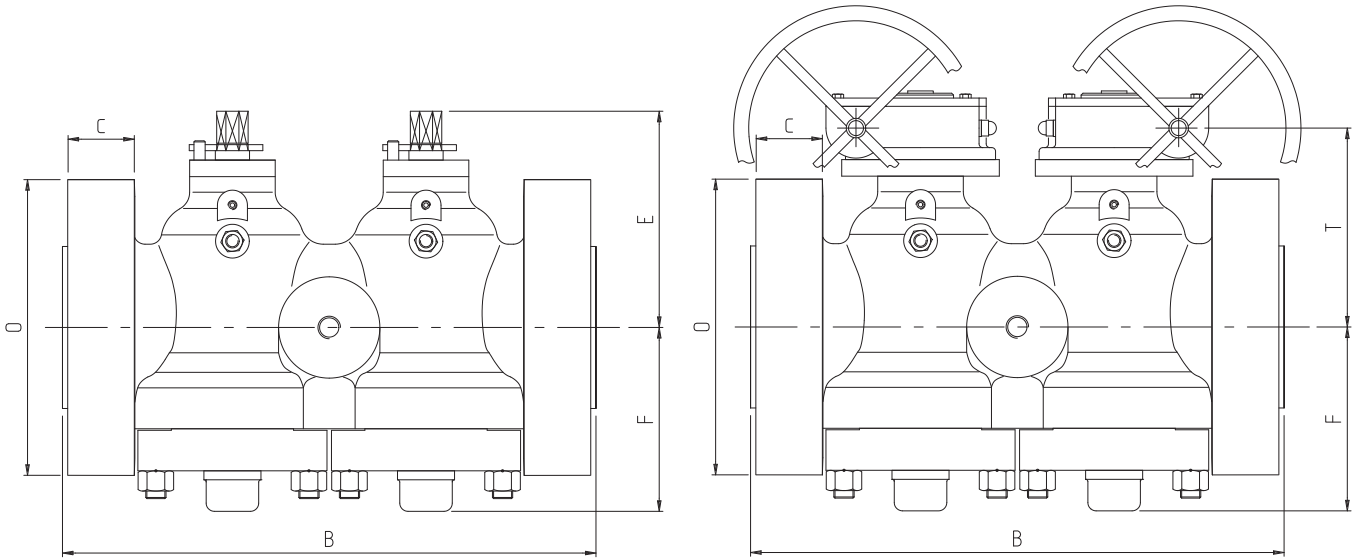

Size	NPS DN	2 50	3 80	4 100	6 150	8 200	10 250	12 300
<b>Face To Face</b>								
RF	<b>B</b>	451	578	673	914	1022	1270	1422
RTJ	<b>B</b>	454	584	683	927	1038	1292	1445
BW	<b>B</b>	451	578	673	914	1022	1270	1422
Flange Diameter	<b>O</b>	235	305	356	483	552	673	762
Flange Thickness	<b>C</b>	51	67	76	108	128	165	185
Top of Stem to Center Line	<b>E</b>	200	–	–	–	–	–	–
Body Cap to Center Line	<b>F</b>	160	210	240	290	330	350	400
Center Line Valve to CL Operator	<b>T</b>	–	190	230	290	370	500	700
Handwheel Diameter	<b>G</b>	–	560	560	700	800	800	800
Length of Wrench	<b>L</b>	100	–	–	–	–	–	–
Size of Bleed Connection MSS SP 45		1/2"	1/2"	1/2"	1/2"	3/4"	3/4"	3/4"

Other size upon request



# API 6A - 2000 - 3000 - 5000 - 10000

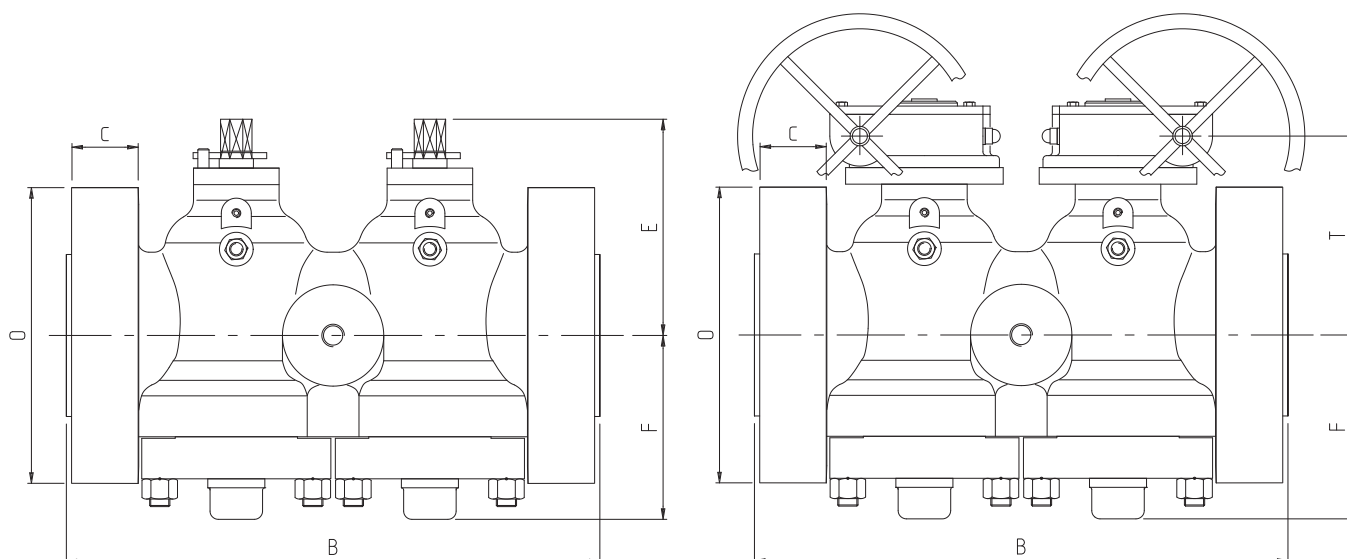

Size	NPS DN	API 2000 - Reduced					API 3000 - Reduced				
		2 <sup>1</sup> / <sub>16</sub> 52	2 <sup>9</sup> / <sub>16</sub> 65	3 <sup>1</sup> / <sub>8</sub> 79	4 <sup>1</sup> / <sub>16</sub> 103	7 <sup>1</sup> / <sub>16</sub> 179	2 <sup>1</sup> / <sub>16</sub> 52	2 <sup>9</sup> / <sub>16</sub> 65	3 <sup>1</sup> / <sub>8</sub> 78	4 <sup>1</sup> / <sub>16</sub> 103	7 <sup>1</sup> / <sub>16</sub> 179
<b>Face To Face</b>											
RTJ	<b>B</b>	295	333	359	435	562	371	422	384	460	613
Flange Diameter	<b>O</b>	165	190	210	273	356	216	245	241	292	381
Flange Thickness	<b>C</b>	26	29	32	38	48	38	42	38	45	56
Top of Stem to Center Line	<b>E</b>	180	180	220	-	-	180	180	218	-	-
Body Cap to Center Line	<b>F</b>	120	120	150	170	200	150	130	170	175	200
Center Line Valve to CL Operator	<b>T</b>	-	-	-	270	280	-	-	-	270	260
Handwheel Diameter	<b>G</b>	-	-	-	560	560	-	-	-	560	560
Length of Wrench	<b>L</b>	500	750	1000	-	-	750	750	1000	-	-
Size of Bleed Connection MSS SP 45		1/2"	1/2"	1/2"	1/2"	3/4"	1/2"	1/2"	1/2"	1/2"	3/4"

Size	NPS DN	API 5000 - Reduced					API 10000 - Full Bore						
		2 <sup>1</sup> / <sub>16</sub> 52	2 <sup>9</sup> / <sub>16</sub> 65	3 <sup>1</sup> / <sub>8</sub> 79	4 <sup>1</sup> / <sub>16</sub> 103	7 <sup>1</sup> / <sub>16</sub> 179	1 <sup>13</sup> / <sub>16</sub> 46	2 <sup>1</sup> / <sub>16</sub> 52	2 <sup>9</sup> / <sub>16</sub> 65	3 <sup>1</sup> / <sub>16</sub> 78	4 <sup>1</sup> / <sub>16</sub> 103	5 <sup>1</sup> / <sub>8</sub> 130	7 <sup>1</sup> / <sub>16</sub> x6 <sup>3</sup> / <sub>8</sub> 179x162
<b>Face To Face</b>													
RTJ	<b>B</b>	371	422	473	549	711							
Flange Diameter	<b>O</b>	216	245	267	311	394							
Flange Thickness	<b>C</b>	38	42	48	54	83							
Top of Stem to Center Line	<b>E</b>	180	210	218	-	-							
Body Cap to Center Line	<b>F</b>	150	180	220	175	225							
Center Line Valve to CL Operator	<b>T</b>	-	-	270	270	265							
Handwheel Diameter	<b>G</b>	-	-	2580	560	710							
Length of Wrench	<b>L</b>	750	1000	-	-	-							
Size of Bleed Connection MSS SP 45		1/2"	1/2"	1/2"	3/4"	1"							

API 10000 - FULL BORE  
UPON REQUEST  
SIZE: 1 13/16" UP TO 7 1/16"





# Hydraulic Pressure Test Duration

In accordance with API 6D and API 598

Valve Size		Test Duration		Valve Size		Test Duration	
DN (mm)	NPS (Inches)	Shell	Seat (1)	DN (mm)	NPS (Inches)	Shell	Seat (1)
<b>API 598</b>				<b>API 6D / ISO 14313</b>			
15 - 50	1/2 - 2	15 sec.	15 sec.	15 - 100	1/2 - 4	2 min.	2 min.
65 - 150	2 1/2 - 6	60 sec.	60 sec.	150 - 250	6 - 10	5 min.	5 min.
200 - 300	8 - 12	120 sec.	120 sec.	300 - 450	12 - 18	15 min.	5 min.
350 and over	14 and over	300 sec.	120 sec.	500 and over	20 and over	30 min.	5 min.

(1) Duration applicable also for the pneumatic seat test (5.5 bar / 80 psi).

## Pressure Test Tables in Accordance with API598 & API 6D

### ASME B16.34 Group Material 1.1

(A 105; A 216 WCB; A 350 LF2)

	Working Pressures by Classes, psig (Bar)					
	150 PN20	300 PN50	600 PN100	900 PN150	1500 PN250	2500 PN420
Working pressure rating	285 (20)	740 (51)	1480 (102)	2220 (153)	3705 (255)	6170 (425)
Hydraulic body test	450 (31)	1125 (78)	2225 (153)	3350 (231)	5575 (384)	9275 (640)
Hydraulic seat test	314 (22)	814 (56)	1628 (112)	2442 (168)	4076 (281)	6787 (468)

### ASME B16.34 Group Material 1.2 and 2.8

(A 350 LF6; A 216 WCC; A 352 LCC; A182 F44/ F51; UNS S31803/S31254/S32750; A 351 Gr. CK3MCuN / CE8MN/ CD4MCu / CD3MWCuN)

	Working Pressures by Classes, psig (Bar)					
	150 PN20	300 PN50	600 PN100	900 PN150	1500 PN250	2500 PN420
Working pressure rating	290 (20)	750 (52)	1500 (103)	2250 (155)	3750 (259)	6250 (431)
Hydraulic body test	450 (31)	1125 (78)	2250 (155)	3375 (233)	5625 (388)	9375 (646)
Hydraulic seat test	319 (22)	825 (57)	1650 (114)	2475 (171)	4125 (284)	6875 (474)

### ASME B16.34 Group Material 1.3

(A 352 LCB)

	Working Pressures by Classes, psig (Bar)					
	150 PN20	300 PN50	600 PN100	900 PN150	1500 PN250	2500 PN420
Working pressure rating	265 (18)	695 (48)	1390 (96)	2085 (144)	3470 (239)	5785 (399)
Hydraulic body test	400 (28)	1050 (72)	2100 (145)	3150 (217)	5225 (360)	8700 (600)
Hydraulic seat test	292 (20)	765 (53)	1529 (105)	2294 (158)	3817 (263)	6364 (439)

### ASME B16.34 Group Material 2.1 and 2.2

(A 182 F304; A 479 Gr. 304; A 351 CF3; A 351 CF8; A 182 F316; A 479 Gr. 316; A 351 CF3M)

	Working Pressures by Classes, psig (Bar)					
	150 PN20	300 PN50	600 PN100	900 PN150	1500 PN250	2500 PN420
Working pressure rating	275 (19)	720 (50)	1440 (99)	2160 (149)	3600 (248)	6000 (414)
Hydraulic body test	425 (29)	1100 (76)	2175 (150)	3250 (224)	5400 (372)	9000 (621)
Hydraulic seat test	303 (21)	792 (55)	1584 (109)	2376 (164)	3960 (273)	6600 (455)

### ASME B16.34 Group Material 2.3

(A 182 F304/F316L; A 479 Gr. 304/316L)

	Working Pressures by Classes, psig (Bar)					
	150 PN20	300 PN50	600 PN100	900 PN150	1500 PN250	2500 PN420
Working pressure rating	230 (16)	600 (41)	1200 (83)	1800 (124)	3000 (207)	5000 (345)
Hydraulic body test	350 (24)	900 (62)	1800 (124)	2700 (186)	4500 (310)	7500 (517)
Hydraulic seat test	253 (17)	660 (46)	1320 (91)	1980 (137)	3300 (228)	5500 (379)

## Pressure Test Tables in Accordance with API6A

Working Pressure Rating		Body				Seat		High Pressure Gas Test Body & Seat	
		Up to 13 5/8"		From 16 3/4"					
Bar	psi	Bar	psi	Bar	psi	Bar	psi	Bar	psi
138	2000	276	4000	207	3000	138	2000	138	2000
207	3000	415	6000	310	4500	207	3000	207	3000
345	5000	517	7500	517	7500	345	5000	345	5000
690	10000	1035	15000	1035	15000	690	10000	690	10000
1035	15000	1550	22500	1550	22500	1035	15000	1035	15000
1380	20000	2070	30000			1380	20000	1380	20000



# Quality Assurance Programme

In accordance with the requirements of the Pressure Equipment Directive 97/23/EC and the Pressure Equipment Regulations 1999 and UK Statutory Instrument 1999 No. 2001

This is to certify that the Quality Management System of:

**Galli & Cassina S.p.A.**  
Solaro (MI)  
Italy

has been assessed against the requirements of Annex III, Module H of the Pressure Equipment Directive 97/23/EC, and Schedule 4, Module H of the Pressure Equipment Regulations 1999 and conforms to the requirements for the products shown below:

**Design and manufacture of manual and actuated plug valves (one way, two way, three way and four way) in carbon, alloy and special alloy from 1/4" to 30" (DN32 to DN750) class rating up to 600lb (100), from 1/4" to 24" (DN32 to DN600) class rating up to 1500lb (PN 250), from 1/4" to 12" (DN32 to DN300) class rating up to 1500lb (PN 420), from 2" to 10" class rating up to API 1**

Approval is subject to the continued maintenance of the quality system in accordance with the requirements of the above Directive and Regulations.

Authorisation is hereby given to use the LR Notified Body Identification Number 0038 in accordance with the requirements of the specified Directive and Regulations for the products as identified above

Certificate No: COV 021  
Date of Issue: 27th Jun  
LR Identification Number 0038

FORM 7004 (03/2000)  
Lloyd's Register of Shipping, registered office



## Certificate of Authority to use the Official API Monogram

License Number: 6A-0520

The American Petroleum Institute hereby grants to

**GALLI & CASSINA S.P.A.**  
Via Drizza, 30/32  
Solaro, Milan  
Italy

to manufacture products under the conditions in the official License Agreement entitled API Spec Q1<sup>®</sup> and API Spec 6A

and the API Monogram should be used in conjunction with this authorization to use the Official API Monogram American Petroleum Institute.

Valves at PSL 1 through 4

American Petroleum Institute  
*John S. Modine*  
Director of Training and Certification Programs

## Certificate of Authority to use the Official API Monogram

License Number: 6D-0049.1

The American Petroleum Institute hereby grants to

**GALLI & CASSINA S.P.A.**  
Via Drizza, 30/32  
Solaro, Milan  
Italy

the right to use the Official API Monogram<sup>®</sup> on manufactured products under the conditions in the official publications of the American Petroleum Institute entitled API Spec Q1<sup>®</sup> and API Spec 6D and in accordance with the provisions of the License Agreement.

In all cases where the Official API Monogram is applied, the API Monogram should be used in conjunction with this certificate number: 6D-0049.1

The American Petroleum Institute reserves the right to revoke this authorization to use the Official API Monogram for any reason satisfactory to the Board of Directors of the American Petroleum Institute.

The scope of this license includes the following product: Plug Valves  
QMS Exclusions: No Exclusions Identified as Applicable

American Petroleum Institute  
*John S. Modine*

American Petroleum Institute







## Quality Assurance System

After 90 years of manufacturing experience and latest technology, Galli&Cassina Quality Assurance System has been assessed, approved and certified against the following quality assurance standards: ISO 9001-Vision 2000 and API Q1. Rigorous procedures and internal audits guarantee that the Quality System is implemented at all stages, starting from incoming raw materials, production, inspection, assembly, final

test, packing and shipping. Every product is designed and manufactured to conform to uniformly high standards. These standards are assured by a quality management system which includes ISO 9001 certification and testing of all products prior to shipment. Advanced design, durable construction materials and rigid manufacturing standard provide valves



you can rely on for years of trouble-free performance. Since its beginning in 1919, Galli&Cassina has maintained its commitment to quality product and satisfied customers. Our focus on product variety, technical expertise and company support remains constant, from drawing board to user satisfaction, our commitment is continuous.

## Quality Assurance Development

Since 1981 Galli&Cassina is authorized to use the monograms of American Petroleum Institute (licence N. 6D - 0049.1) (licence N. 6A - 0520). As a guarantee and certification of the Quality Assurance Program implemented, Galli&Cassina has the quality system issued by Lloyd's Register certifying that Galli&Cassina Quality System conforms to the European Standard ISO 9001: 2000, API Spec. Q1, and is always subject by internal/ external audit to be in compliance with

the customer requirements. In addition Galli&Cassina Plug Valves are in compliance with CE Pressure Equipment Directive PED N. 97/23/EC and ATEX (N. 94 /9 /EC) for products intended for use in potentially explosive atmospheres.



## Customer Service

Galli&Cassina's Customer Service is always willing to assist the customer with a prompt response to "service" requests. Full after sales services assistance can be offered either at our workshop or on site testing, spare parts supply;

Training programs, on operation and safety; Final-Documentation.







## Lubricants

**Galli&Cassina Plug Valves can use different types of Climax lubricant grease suitable for various services.**

**The operating conditions must be specified at enquiry stage enabling us to advise which type of sealant is suitable.**

**The lubricant grease is available as a spare part item and can be ordered as:**



- **Cartridges (suitable for hydraulic gun pump).**
  - **Drums (suitable for pneumatic pump).**
- For the selection of the correct lubricant, Galli&Cassina staff is always available at the customer's request to recommend the suitable lubricant.**

## Climax Hydraulic Gun No.1699



This specially designed, high pressure handgun, light in weight (appr. 16lbs.) is more rugged than conventional types and meets exacting demands of plug valve sealants. Built for servicing plug valves, all parts are machined with minutye accuracy.

The polished hardened steel piston is perfectly fitted in the high pressure barrel to provide absolute smoothness of operation. The CLIMAX 1699 is self-priming and can be used in any position. Because of its hydraulic principle, this gun exerts more pressure than any other portable gun.

This gun is equipped with a CLIMAX 1699 Button Head Coupler for connection to the button head sealant fitting in the shank of the valve.

This coupler has a built - in feature which locks it to fitting when the gun is under positive pressure.

The coupler cannot be connected to or separated from the fitting with the gun under pressure. This pressure may be relieved by a turn of the by-pass valve on the gun. The by-pass valve should not be closed to a point where it is jammed into its seat, nor should it be opened tight against the stop.

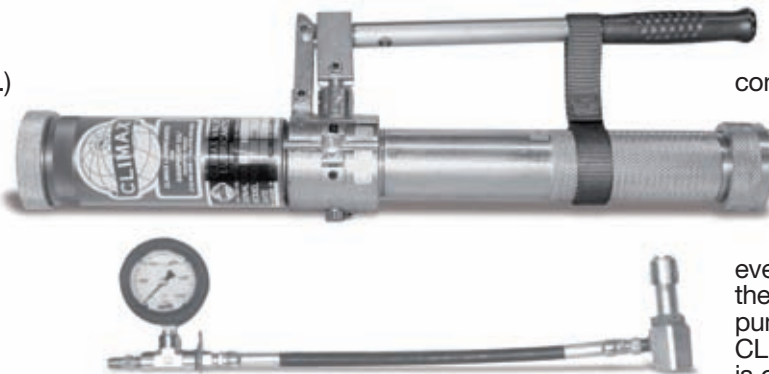

The valve should be closed firmly, but no tightly. It is not necessary to open the valve past one full turn. Due to "built - in" safety features, the CLIMAX 1699

provides the maximum safety to both the valve and the gun itself. The hydraulic system of the gun is equipped with a relief fitting to protect the

gun from injury if the operator were to continue to pump after the gun had been depleted of valve sealant.

Also, to prevent damage to the valve and sealant gun, in the event of sealant clogging the system or the operator pumping too fast, a CLIMAX 15000 psi gauge is optional equipment. This accessory indicates the point at which sufficient sealant pressure has been developed within the valve.

The gauge also indicates valve adjustment and other services required. The CLIMAX 0 -15000 psi gauge is the highest quality, most reliable glycerin filled gauge available.

The one piece die cast brass case and heavy duty bourdon tube and movement enable the gauge to stand up to the shock and vibration encountered on the most demanding applications. The CLIMAX gauge also features a rubber gauge protector.

A carrying case for the CLIMAX Model 1699 is optional. Refer to the part list for available options.

Note: Gun shown is a 1699-S model complete with hose assembly, gauge, tee and "Z" swivel.

## Automatic Lubrication

**Galli&Cassina Plug Valves can be provided with a special automatic lubricant pump to facilitate lubrication maintenance service.**

**The automatic pump model depends on the size of valve and its number of open/closed cycles enables**

**us to calculate the consumption of the lubricant grease during the operating service. The automatic pumps are available either electric or pneumatic motor type at the following operating temperature range: -20 to 40°C.**



# Climax Lubricants

Lubricant and No.	Type Available	Color	Temp. Range From To	Principal Services	Unsuitable For
220	Stick Bulk	Clear	-75 to 250 °F -59 to 121 °C	Very cold service for pipe lines, compressor stations, gasoline plants and crude oil production fields. For Liquid Service.	Aromatic, Solvents.
262	Stick		-85 to 250 °F -65 to 121 °C	Same as above-Gas Service.	LPG
400	Stick Bulk	Red	-20 to 450 °F -29 to 232 °C	Acids and Caustics.	Liquid Hydrocarbons.
600	Stick Bulk	Tan Brown	-20 to 500 °F -29 to 260 °C	General gas and general Hydrocarbons service.	LPG
650	Stick Bulk	Blue-Green	-40 to 500 °F -40 to 260 °C	Hydrocarbon and L.P.G. service	Aromatic, Alkalies Solvents.
711	Stick Bulk	White	32 to 400 °F 0 to 204 °C	Aviation gasoline, Jet fuel, fuel blends of Alkylate.	100% Benzine.
750	Stick Bulk	Black	0 to 600 °F -18 to 316 °C	Asphalt hot oil service Salt brine, high temperature steam.	Aromatic, Alkalies Solvents.
800	Stick Bulk	White	-20 to 450 °F -29 to 232 °C	Butane, Butadiene, Carbon Tetrachloride, Ethane, Propane.	Alkalies
900	Stick Bulk	Black	-20 to 650 °F -29 to 343 °C	Natural gas, petrochemical plants, rubber plants, and hot Hydrocarbons service.	Alkalies
901	Stick Bulk	Black	-30 to 300 °F -34 to 149 °C	Cold weather, Hydrocarbon lubricant.	Alkalies
950	Stick Bulk	Amber	-40 to 300 °F -40 to 149 °C	Propylenes, Benzenes Toulene, Butadiene, Xylenes, Styrene, Cumenes	Alkalies
1034-MT	Stick Bulk	Cream	-20 to 400 °F -29 to 204 °C	Liquid and gaseous. Aliphatic hydrocarbon service. (wet or dry natural gas)	Alkalies





## Fire Safe Test

*All Galli&Cassina's Plug Valves have been tested against fire resistance, according to API - 6FA and BS 6755 - Part 2 standards and witnessed by international third party.*



*Metal to Metal Seat, diaphragm sealing as well as the stem sealing compound with graphite guarantees a high reliability performance of our Plug Valves while in exposure to Fire Test conditions.*

## Available Tests

Type of Test	Applicable Standards	Performance
X AND GAMMA RAYS	ANSI B16.34 - Annex-B ASME VIII - Div.1 - MSS - SP 54 ASTM E446 - E186 - E280	100% all butt welding ends and body.
DYE PENETRANT	ASME V - art.6 and 24 - ASTM E142 ANSI B16.34 - Annex-D MSS-SP-93	100% All butt welding ends
MAGNETIC - PARTICLES (Dry and wet)	ASME V - art.7 and 25 ANSI B16.34 - Annex C - MSS - SP 53	100% of all valves
ULTRASONIC	ASME V - art.4 and 23 ASME VIII - Div.1 - ASTM - A388	Upon customer request
VISUAL AND DIMENSIONAL	MSS - SP 55 ANSI B16.5 - B16.10 API 6D - (Table 4.2)	100% of rough and finished machined components and assembled valves
HARDNESS	NACE - MR.01.75 Latest Edition	100% of wetted components
HYDROSTATIC AND PNEUMATIC	API - 6D - API 598 BS 6755 - Part.1 - MSS - SP 61	100% of all valves
OPERATION TORQUE	API - 6D	Upon customer request
HIGH PRESSURE CLOSURE	API - 598 - Par. 4-5	Upon customer request
POSITIVE MATERIAL IDENTIFICATION	ASTM A751	100% of pressure containing components







# Temperature Conversion Table

$$^{\circ}\text{C} = \frac{5}{9} (^{\circ}\text{F} - 32)$$

$$^{\circ}\text{F} = \frac{9}{5} ^{\circ}\text{C} + 32$$

$^{\circ}\text{C}$		$^{\circ}\text{F}$	$^{\circ}\text{C}$		$^{\circ}\text{F}$
-273	-459.4		43.3	110	230.0
-268	-450		46.1	115	239.0
-240	-400		48.9	120	248.0
-212	-350		54.4	130	266.0
-184	-300		60.0	140	284.0
-157	-250	-418	65.6	150	302.0
-129	-200	-328	71.1	160	320.0
-101	-150	-238	76.7	170	338.0
- 73	-100	-148	82.2	180	356.0
- 45.6	- 50	- 58.0	87.8	190	374.0
- 42.8	- 45	- 49.0	93.3	200	392.0
- 40.0	- 40	- 40.0	98.9	210	410.0
- 37.2	- 35	- 31.0	104.4	220	428.0
- 34.4	- 30	22.0	110.0	230	446.0
- 31.7	- 25	- 13.0	115.6	240	464.0
- 28.9	- 20	- 4.0	121.0	250	482.0
- 26.1	- 15	5.0	149.0	300	572.0
- 23.2	- 10	14.0	177.0	350	662.0
- 20.6	- 5	23.0	204.0	400	752.0
- 17.8	<b>0</b>	32.0	232.0	450	842.0
- 15.0	5	41.0	260.0	500	932.0
- 12.2	10	50.0	288.0	550	1022.0
- 9.4	15	59.0	316.0	600	1112.0
- 6.7	20	68.0	343.0	650	1202.0
- 3.9	25	77.0	371.0	700	1292.0
- 1.1	30	86.0	399.0	750	1382.0
<b>0</b>	32	89.6	427.0	800	1472.0
7.7	35	95.0	454.0	850	1562.0
4.4	40	104.0	482.0	900	1652.0
7.2	45	113.0	510.0	950	1742.0
10.0	50	122.0	538.0	1000	1832.0
12.8	55	131.0	566.0	1050	1922.0
15.6	60	140.0	593.0	1100	2012.0
18.3	65	149.0	621.0	1150	2102.0
21.1	70	158.0	649.0	1200	2192.0
23.9	75	167.0	677.0	1250	2282.0
26.7	80	176.0	704.0	1300	2372.0
29.4	85	185.0	732.0	1350	2462.0
32.2	90	194.0	762.0	1400	2552.0
35.0	95	203.0	788.0	1450	2642.0
37.8	100	212.0	816.0	1500	2732.0
40.6	105	221.0			

**NOTE:** The temperature to be converted is the figure in the yellow column.  
To obtain a reading in  $^{\circ}\text{C}$  use left column; for conversion to  $^{\circ}\text{F}$  use the right column.



## Pressure/Temperature Rating According to ASME B16.34-2009

### Material: ASTM A 105, ASTM A 216 Gr. WCB, ASTM A 350 Gr. LF2 (Table 2-1.1)

Temperature	Working Pressures by Classes, psig (Bar)					
°F (°C)	150	300	600	900	1500	2500
-20 to 10 (-29 to 38)	285 (20)	740 (51)	1.480 (102)	2.220 (153)	3.705 (255)	6.170 (425)
200 ( 93)	260 (18)	680 (47)	1.360 ( 94)	2.035 (140)	3.395 (234)	5.655 (390)
300 (149)	230 (16)	655 (45)	1.310 ( 90)	1.965 (135)	3.270 (225)	5.450 (377)
400 (204)	200 (14)	635 (44)	1.265 ( 87)	1.900 (131)	3.170 (219)	5.280 (364)
500 (260)	170 (12)	605 (42)	1.205 ( 83)	1.810 (125)	3.015 (208)	5.025 (346)
600 (316)	140 (10)	570 (39)	1.135 ( 78)	1.650 (114)	2.840 (196)	4.730 (326)
650 (343)	125 ( 9)	550 (38)	1.100 ( 76)	1.650 (114)	2.745 (189)	4.575 (315)
700 (371)	110 ( 8)	530 (37)	1.060 ( 73)	1.590 (110)	2.665 (184)	4.425 (305)

### Material: ASTM A 216 Gr. WCC, ASTM A 352 Gr. LCC/LC2/LC3 (Table 2-1.2)

Temperature	Working Pressures by Classes, psig (Bar)					
°F (°C)	150	300	600	900	1500	2500
-20 to 10 (-29 to 38)	290 (20)	750 (52)	1.500 (103)	2.250 (155)	3.750 (259)	6.250 (431)
200 ( 93)	260 (18)	750 (52)	1.500 (103)	2.250 (155)	3.750 (259)	5.250 (431)
300 (149)	230 (16)	730 (50)	1.455 (100)	2.185 (151)	3.640 (251)	6.070 (419)
400 (204)	200 (14)	705 (49)	1.410 ( 97)	2.110 (145)	3.520 (243)	5.865 (404)
500 (260)	170 (12)	665 (46)	1.330 ( 92)	1.995 (138)	3.325 (229)	5.540 (382)
600 (316)	140 (10)	605 (42)	1.210 ( 83)	1.815 (125)	3.025 (209)	5.040 (348)
650 (343)	125 ( 9)	590 (41)	1.175 ( 81)	1.765 (122)	2.940 (203)	4.905 (338)
700 (371)	110 ( 8)	555 (38)	1.110 ( 77)	1.705 (118)	2.775 (191)	4.630 (319)

### Material: ASTM A 352 Gr. LCB (Table 2-1.3)

Temperature	Working Pressures by Classes, psig (Bar)					
°F (°C)	150	300	600	900	1500	2500
-20 to 10 (-29 to 38)	265 (18)	695 (48)	1.395 (96)	2.090 (144)	3.480 (240)	5.805 (400)
200 ( 93)	255 (18)	655 (45)	1.320 (91)	1.980 (137)	3.300 (228)	5.505 (380)
300 (149)	230 (16)	640 (44)	1.275 (88)	1.915 (132)	3.190 (220)	5.315 (366)
400 (204)	200 (14)	615 (42)	1.230 (85)	1.845 (127)	3.075 (212)	5.125 (353)
500 (260)	170 (12)	585 (40)	1.175 (81)	1.760 (121)	2.930 (202)	4.885 (337)
600 (316)	140 (10)	550 (38)	1.105 (76)	1.655 (114)	2.755 (190)	4.595 (317)
650 (343)	125 ( 9)	535 (37)	1.065 (73)	1.600 (110)	2.665 (184)	4.440 (306)
700 (371)	110 ( 8)	510 (35)	1.025 (71)	1.535 (106)	2.560 (177)	4.270 (294)

### Material: ASTM A 182 Gr. F316/F316H, ASTM A 479 Gr. 316/316H, ASTM A 351Gr. CF3M/CF8M (Table 2-2.2)

Temperature	Working Pressures by Classes, psig (Bar)					
°F (°C)	150	300	600	900	1500	2500
-20 to 10 (-29 to 38)	275 (19)	720 (50)	1.440 (99)	2.160 (149)	3.600 (248)	6.000 (414)
200 ( 93)	235 (16)	620 (43)	1.240 (85)	1.860 (128)	3.095 (213)	5.160 (356)
300 (149)	215 (15)	560 (39)	1.120 (77)	1.680 (116)	2.795 (193)	4.660 (321)
400 (204)	195 (13)	515 (36)	1.025 (71)	1.540 (106)	2.570 (177)	4.280 (295)
500 (260)	170 (12)	480 (33)	955 (66)	1.435 ( 99)	2.390 (165)	3.980 (274)
600 (316)	140 (10)	450 (31)	900 (62)	1.355 ( 93)	2.255 (155)	3.760 (259)
650 (343)	125 ( 9)	440 (30)	885 (61)	1.325 ( 91)	2.210 (152)	3.680 (254)
700 (371)	110 ( 8)	435 (30)	870 (60)	1.305 ( 90)	2.170 (150)	3.620 (250)



# Chemical and Mechanical Requirements - Forged / bar

		Composition % (Maximum Percent Unless Range is Given)						
	ASTM Standard (UNS designation)	Nominal Composition	C	Mn	P	S	Si	
Carbon Steel	A 105 (1) (2) (3)		0,35	0,60 - 1,05	0,035	0,040	0,10-0,35	
	A 350 LF1 (2) (3)		0,30	0,60-1,35	0,035	0,040	0,15-0,30	
	A 350 LF2 (2) (3)		0,30	0,60 - 1,35	0,035	0,040	0,15- 0,30	
Low Alloy	A 350 LF3 (3)		0,20	0,90	0,035	0,040	0,20-0,35	
	A 29 Gr.4140		0,38 - 0,43	0,75 - 1,00	0,035	0,040	0,15- 0,35	
	A 29 Gr.4340		0,38-0,43	0,60-0,80	0,035	0,040	0,15-0,35	
	A 182 F1	(UNS K12822)	C-Mo	0,28	0,60-0,90	0,045	0,045	0,15-0,35
	A 182 F2	(UNS K12122)	0,5Cr-0,5Mo	0,05-0,21	0,30-0,80	0,040	0,040	0,10-0,60
	A 182 F5a	(UNS K42544)	5Cr	0,25	0,60	0,040	0,030	0,50
	A 182 F9	(UNS K90941)	9Cr	0,15	0,30-0,60	0,030	0,030	0,50-1,00
	A 182 F11 CL.3	(UNS K11572)	1,25Cr-0,5Mo	0,10-0,20	0,30-0,80	0,040	0,040	0,50-1,00
	A 182 F12 CL.2	(UNS K11564)	1Cr-0,5Mo	0,10-0,20	0,30-0,80	0,040	0,040	0,10-0,60
	A 182 F22 CL.3	(UNS K21590)	Cr-Mo	0,05-0,15	0,30-0,60	0,040	0,040	0,50
	Martensitic	A182 F6a CL.2	(UNS S41000)	13Cr	0,15	1,00	0,040	0,030
A 182 F6NM		(UNS S41500)	13Cr-4Ni	0,05	0,5-1,0	0,030	0,030	0,60
Austenitic Stainless Steel	A 182 F304 (4)	(UNS S30400)	18Cr-8Ni	0,08	2,00	0,045	0,030	1,00
	A 182 F304H (4)	(UNS S30409)	18Cr-8Ni	0,04-0,10	2,00	0,045	0,030	1,00
	A 182 F304L (4)	(UNS S30403)	18Cr-8Ni	0,035	2,00	0,045	0,030	1,00
	A 182 F316 (4)	(UNS S31600)	18Cr-10Ni-Mo	0,08	2,00	0,045	0,030	1,00
	A 182 F316H (4)	(UNS S31609)	18Cr-10Ni-Mo	0,04-0,10	2,00	0,045	0,030	1,00
	A 182 F316L (4)	(UNS S31603)	18Cr-10Ni-Mo	0,030	2,00	0,045	0,030	1,00
	A 182 F310	(UNS S31000)	25Cr-20Ni	0,25	2,00	0,045	0,030	1,00
	A 182 F44	(UNS S31254)	20Cr-18Ni-6Mo	0,020	1,00	0,030	0,010	0,80
	B 462- UNS N08020	(ALLOY 20)	29Ni-20Ni-3Cu-2Mo	0,07	2,00	0,045	0,035	1,00
Austenitic Ferritic Stainless Steel	A 182 F51	(UNS S31803)	22Cr-5Ni	0,030	2,00	0,030	0,020	1,00
	A 182 F53	(UNS S32750)	25Cr-7Ni-4Mo	0,030	1,20	0,035	0,020	0,80
	A 182 F55	(UNS S32760)(5)	25Cr-7Ni-3,5Mo	0,030	1,00	0,030	0,010	1,00
Age hardened SS	A 564 Gr 630 H900	(UNS S17400)	16Cr-4Ni-4Cu	0,07	1,00	0,040	0,030	1,00
	A 564 Gr 630 H1150M	(UNS S17400)	16Cr-4Ni-4Cu	0,07	1,00	0,040	0,030	1,00
Titanium	B 348 Gr.3	(Unalloyed Titanium)	Ti	0,08	Ti=Balance	H=0,015	Fe=0,30	O=0,35
	B 348 Gr.5	(Titanium Alloy)	6Al-4V	0,08	Ti=Balance	H=0,015	Fe=0,40	O=0,20
Nickel Alloy	B 564-UNS N06625	(INCONEL 625)	60Ni-22Cr-9Mo-3,5Cb	0,10	0,5	0,015	0,015	0,5
	B 564-UNS N08825	(INCONEL 825)		0,05	1,0		0,03	0,5

(1) For each reduction of 0,01% below the specified maximum carbon content, an increase of 0,06% Mn above the specified maximum will be permitted up to a maximum of 1,35%.

(2)  $Cu + Ni + Cr + Mo \leq 1,00\%$





# Materials for Body, Plug, Cover and Stem Components

						Mechanical Properties			
Cr	Mo	Ni	Cu	V	Others Elements	Tensile Strength min, ksi (MPa)	Yield Strength min, ksi (MPa)	Elongation min%	Reduction of area min%
0,30	0,12	0,40	0,40	0,08	Cb = 0,02	70 (485)	36 (250)	22	30
0,30	0,12	0,40	0,40	0,08	Cb=0,02	60 (415)	30 (205)	25	38
0,30	0,12	0,40	0,40	0,08	Cb=0,02	70 (485)	36 (250)	22	30
0,30	0,12	3,3 - 3,7	0,40	0,03	Cb=0,02	70 (485)	37,5 (260)	22	35
0,80-1,10	0,15-0,25	-	-	-	-	100 (690)	75 (520)	20	50
0,70-0,90	0,20-0,30	1,65-2,00	-	-	-	115 (790)	96 (660)	16	45
-	0,44-0,65	-	-	-	-	70 (485)	40 (275)	20	30
0,50-0,81	0,44-0,65	-	-	-	-	70 (485)	40 (275)	20	30
4,0-6,0	0,44-0,65	0,50	-	-	-	90 (620)	65 (450)	22	50
8,0-10,0	0,90-1,10	-	-	-	-	85 (585)	55 (380)	20	40
1,00-1,50	0,44-0,65	-	-	-	-	75 (515)	45 (310)	20	30
0,80-1,25	0,44-0,65	-	-	-	-	70 (485)	40 (275)	20	30
2,00-2,50	0,87-1,13	-	-	-	-	75 (515)	45 (310)	20	30
11,5-13,5	-	0,50	-	-	-	85 (585)	55 (380)	18	35
11,5-14,0	0,5-1,0	3,5-5,5	-	-	-	115 (790)	90 (620)	15	45
18,0-20,0	-	8,0-11,0	-	-	-	75 (515)	30 (205)	30	50
18,0-20,0	-	8,0-11,0	-	-	-	75 (515)	30 (205)	30	50
18,0-20,0	-	8,0-13,0	-	-	-	70 (485)	25 (170)	30	50
16,0-18,0	2,00-3,00	10,0-14,0	-	-	-	75 (515)	30 (205)	30	50
16,0-18,0	2,00-3,00	10,0-14,0	-	-	-	75 (515)	30 (205)	30	50
16,0-18,0	2,00-3,00	10,0-15,0	-	-	-	70 (485)	25 (170)	30	50
19,0-22,0	-	24,0-26,0	-	-	-	75 (515)	30 (205)	30	50
19,5-20,5	6,0-6,5	17,5-18,5	0,5-1,0	-	N=0,18-0,22	94 (650)	44 (300)	35	50
19,00-21,00	2,00-3,00	32,00-38,00	3,00-4,00	-	-	80 (551)	35 (241)	30	50
21,0-23,0	2,5-3,5	4,5-6,5	-	-	N=0,08-0,20	90 (620)	65 (450)	25	45
24,0-26,0	3,0-5,0	6,0-8,0	0,5	-	N=0,24-0,32	116 (800)	80 (550)	15	-
24,0-26,0	3,0-4,0	6,0-8,0	0,50-1,00	N=0,20-0,30	W=0,50-1,00	109 (750)	80 (550)	25	45
15,0-17,5	-	3,00-5,00	3,00-5,00	-	-	190 (1.310)	170 (1.170)	10	40
15,0-17,5	-	3,00-5,00	3,00-5,00	-	-	115 (795)	75 (515)	18	55
-	-	-	-	-	N=0,05	65 (450)	55 (380)	18	30
Al=5,5-6,75	-	-	-	3,5-4,5	N=0,05	130 (895)	120 (828)	10	25
20,0-23,0	8,0-10,0	58,0Min	Ta+Cb=3,15-4,15	Ti=0,4	Fe=5,0Al=0,4	110 (758)	50 (345)	25	-
19,5-23,5	2,5-3,5	38,0-46,0	1,5-3,0	Ti=0,6-1,2	Fe=22,0Al=0,2	85 (586)	35 (241)	30	-

(3)  $Cr + Mo \leq 0,32\%$

(4) Maximum nitrogen content of 0,10%

(5) Pitting Resistance Equivalent Number (PREN) =  $Cr + 3,3Mo + 16N \leq 40$ .



## Chemical and Mechanical Requirements - Cast Materials

Composition % (Maximum Percent Unless Range is Given)							
	ASTM Standard (UNS designation)	Nominal Composition	C	Mn	P	S	Si
Carbon Steel	A 216 WCB (2)		0,30	1,00	0,04	0,045	0,60
	A 216 WCC (2)		0,25	1,20	0,04	0,045	0,60
	A 352 LCB (UNS J03003) (2)		0,30	1,00	0,04	0,045	0,60
	A 352 LCC (UNS J02505) (2)		0,25	1,20	0,04	0,045	0,60
	A 352 LC3 (UNS J31550)	3,5Ni	0,15	0,50-0,80	0,04	0,045	0,60
	A 487 Gr4Q 4-C	Ni-Cr-Mo	0,03	1,00	0,04	0,045	0,80
Low Alloy	A 217 WC1	C-Mo	0,25	0,50-0,80	0,04	0,045	0,60
	A 217 WC6	Cr-Mo	0,05-0,20	0,50-0,80	0,04	0,045	0,60
	A 217 WC9	Cr-Mo	0,05-0,18	0,40-0,70	0,04	0,045	0,60
	A 217 C5	Cr-Mo	0,20	0,40-0,70	0,04	0,045	0,75
	A 217 C12	Cr-Mo	0,20	0,35-0,65	0,04	0,045	1,00
Martensitic	A 217 CA15 (UNS J91150)	13Cr	0,15	1,00	0,04	0,04	1,50
	A 487 CA6NM (UNS J91540)	13Cr-4Ni	0,06	1,00	0,04	0,03	1,00
Austenitic Stainless Steel	A 351 CF3 (UNS J92500)	18Cr-8Ni	0,03	1,50	0,04	0,04	2,00
	A 351 CF3M (UNS J92800)	16Cr-12Ni-2Mo	0,03	1,50	0,04	0,04	1,50
	A 351 CF8 (UNS J92600)	18Cr-8Ni	0,08	1,50	0,04	0,04	2,00
	A 351 CF8C (UNS 92710) (1)	18Cr-10Ni-2Co	0,08	1,50	0,04	0,04	2,00
	A 351 CF8M (UNS J92900)	16Cr-12Ni-2Mo	0,08	1,50	0,04	0,04	1,50
	A 351 CN7M (UNS N08007)	29Ni-20Cr-3Cu-2Mo	0,07	1,50	0,04	0,04	1,50
	A 351 CK3MCuN (UNS J93254) (3)	20Cr-18Ni-6Mo-N	0,025	1,20	1,00	0,010	0,045
Cast Austenitic Ferritic (Duplex) Stainless Steel	A 890 CD3MN (UNS J92205)	22Cr-5Ni-Mo-N	0,03	1,50	0,04	0,020	1,00
	A 890 CE3MN (UNS J93404) (3)	25Cr-7Ni-Mo-N	0,03	1,50	0,04	0,04	1,00
	A 890 CD3MWCuN (UNS J93380)(3)	25Cr-7Ni-Mo-N	0,03	1,00	0,030	0,025	1,00

## Chemical and Mechanical Requirements Bolting Materials

Stud	A 193 B7 and B7M (5)	Cr-Mo	0,37-0,49	0,65-1,10	0,035	0,040	0,15-0,35
	A 193 B16	Cr-Mo-V	0,36-0,47	0,45-0,70	0,035	0,040	0,15-0,35
	A 193 B8M CL.2	18Cr-10Ni-2Mo	0,08	2,00	0,045	0,030	1,00
	A 320 L43	Ni-Cr-Mo	0,38-0,43	0,60-0,85	0,035	0,040	0,15-0,35
	A 320 L7 and L7M (5)	Cr-Mo	0,38-0,48	0,75-1,00	0,035	0,04	0,15-0,35
	A 453 Gr 660A		0,08	2,00	0,040	0,030	1,00
Nut	A 194 2H/2HM	C	min 0,40	1,00	0,040	0,050	0,40
	A 194 4	C-Mo	0,40-0,50	0,70-0,90	0,035	0,040	0,15-0,35
	A 194 7/7M	Cr-Mo	0,37-0,49	0,65-1,10	0,035	0,040	0,15-0,35
	A 194 8M	18Cr-10Ni-2Mo	0,08	2,00	0,045	0,030	1,00

- (1) Grade CF8C shall have a columbium content of not less than 8 times the carbon content but not over 1,00%  
 (2) For each reduction of 0,01% below the specified maximum carbon content, and increase of 0,04% Mn above the specified maximum will be permitted up to a maximum of: 1,28% for WCB and LCB; 1,40% for WCC and LCC.



# for Body, Plug and Cover Components

						Mechanical Properties			
Cr	Mo	Ni	Cu	V	W	Tensile Strength min, ksi (MPa)	Yield Strength min, ksi (MPa)	Elongation min%	Reduction of area min%
0,50	0,20	0,50	0,30	0,03	-	70 (485)	36 (250)	22	35
0,50	0,20	0,50	0,30	0,03	-	70 (485)	40 (275)	22	35
0,50	0,20	0,50	0,30	0,03	-	65 (450)	35 (240)	24	35
0,50	0,20	0,50	-	0,03	-	70 (485)	40 (275)	22	35
	0,30-0,60	3,00-4,00	-	-	-	7 (485)	40 (275)	24	35
0,40-0,80	0,15-0,30	0,4-0,80	0,50	0,03	0,10	90 (620)	60 (415)	18	35
0,35	0,45-0,65	-	0,50	-	0,10	65 (450)	35 (240)	24	35
1,00-1,50	0,45-0,65	0,50	0,50	-	0,10	70 (485)	40 (275)	20	35
2,00-2,75	0,90-1,20	0,50	0,50	-	0,10	70 (485)	40 (275)	20	35
4,00-6,50	0,45-0,65	0,50	0,50	-	0,10	90 (620)	60 (415)	18	35
8,00-10,00	0,90-1,20	0,50	0,50	-	0,10	90 (620)	60 (415)	18	35
11,50-14,00	0,50	1,00	-	-	-	90 (620)	65 (450)	18	30
11,5-14,0	0,4-1,0	3,5-4,5	0,50	0,05	0,10	100 (690)	75 (515)	17	35
17,00-21,00	0,50	8,00-12,00	-	-	-	70 (485)	30 (206)	35	-
17,00-21,00	2,00-3,00	9,00-13,00	-	-	-	70 (485)	30 (206)	30	-
18,00-21,00	0,50	8,00-11,00	-	-	-	70 (485)	30 (206)	35	-
18,00-21,00	0,50	9,00-12,00	-	-	-	70 (485)	30 (206)	30	-
18,00-21,00	2,00-3,00	9,00-12,00	-	-	-	70 (485)	30 (206)	30	-
19,0-22,0	2,0-3,0	27,5-30,5	3,0-4,0	-	-	62 (425)	25 (170)	35	-
19,5-20,5	6,0-7,0	17,5-19,5	0,50-1,00	-	N=0,18-0,24	80 (550)	38 (260)	35	-
21,0-23,5	2,5-3,5	4,5-6,5	1,00	-	N=0,10-0,30	90 (620)	60 (415)	25	-
24,0-26,0	4,0-5,0	6,0-8,0	-	-	N=0,10-0,30	100 (690)	75 (515)	18	-
24,0-26,0	3,0-4,0	6,5-8,5	0,5-1,0	N=0,20-0,3	0,5-1,0	100 (690)	65 (450)	25	-

## (Body / Plug)

0,75-1,20	0,15-0,25	-	-	-	-	125/100 (860/690)	105/80 (720/550)	16/18	50
0,80-1,15	0,50-0,65	-	-	0,25-0,35	Al=0,015	125 (860)	105 (725)	18	50
16,0-18,0	2,00-3,00	10,0-14,0	-	-	-	100 (690)	80 (550)	(4)	45
0,70-0,90	0,20-0,30	1,65-2,00	-	-	-	125 (860)	105 (725)	16	50
0,80-1,10	0,15-0,25	-	-	-	-	125/100 (860/690)	105/80 (725/550)	16	50
13,5-16,0	1,00-1,50	24,0-27,0	-	0,10-0,50	B=0,001-0,01 Ti=1,90-2,35	130 (895)	85 (585)	15	18
-	-	-	-	-	-	--	--	-	-
-	0,20-0,30	-	-	-	-	--	--	-	-
0,75-1,20	0,15-0,25	-	-	-	-	--	--	-	-
16,0-18,0	2,00-3,00	10,0-14,0	-	-	-	--	--	-	-

(3) Pitting Resistance Equivalent Number (PREN) = Cr + 3,3Mo + 16N ≤ 40.

(4) For 3/4" (M20) and under: 110/(760), 95/(655) 15; over 3/4" (M20) up to 1" (M24): 100/(690), 80/(550), 20 over 1" M24 up to 1.25" (M30) 95/(655), 65/(450), 25 over 1.25" (M30) up to 1.5" (M36): 90/(620), 50/(345), 30.

(5) For B7M and L7M grades, a minimum carbon content of 0,28% is permitted, provided that the required tensile properties are met in the section size involved.





## Qualification of other Size Valves - API 6FA

### Size of Test Valve

NPS	DN	NPS	DN
2 API 6D	50	2 - 2 1/2 - 3 - 4 API 6D	50 - 65
1 13/16 - 2 1/16 API 6A		1 13/16 - 2 1/16 - 2 9/16 - 3 1/8 - 4 1/16 API 6A	80 - 100
2 9/16 API 6A	65	2 9/16 - 3 1/8 - 4 1/16 - 5 1/8 API 6A	65 - 80
2 1/2 API 6D		2 1/2 - 3 - 4 API 6D	100 - 125
3 API 6D	80	3 - 4 - 6 API 6D	80 - 100
3 9/16 API 6A		3 1/8 - 4 1/16 - 5 1/8 - 7 1/16 API 6A	125 - 150
4 API 6D	100	4 - 6 - 8 API 6D	100 - 125
4 1/16 API 6A		4 1/16 - 5 1/8 - 7 1/16 API 6A	150 - 200
6 API 6D	150	6 - 8 - 10 - 12 API 6D	150 - 200
7 1/16 API 6A		7 1/16 - 9 - 11 API 6A	250 - 300
8 API 6D	200	8 - 10 - 12 - 14 - 16 API 6D	200 - 250
		9 - 11 API 6A	300 - 350 - 400
10 API 6D	250	10 through 20 API 6D	250 through
		11 API 6A	500
12 API 6D	300	12 through 24 API 6D	300 through 600
14 API 6D	350	14 through 28 API 6D	350 through 700
16 API 6D	400	16 and larger 24 API 6D	400 and larger

## Qualification of other Pressure Rating Valves

### Rating of Test Valve

Class	PN	Bar	Class	PN	Bar
150 API 6D	20	N/A	150 - 300 API 6D	20 - 50	N/A
300 API 6D	50	N/A	300 - 400 - 600 API 6D	50 - 64 - 110	N/A
400 API 6D	64	N/A	400 - 600 API 6D	64 - 110	N/A
600 API 6D	110	N/A	600 - 900 API 6D	110 - 150	N/A
			2000 - 3000 API 6A	N/A	138 - 207
900 API 6D	150	N/A	900 - 1500 API 6D	150 - 260	N/A
			3000 API 6A	N/A	207
1500 API 6D	260	N/A	1500 - 2500 API 6D	260 - 420	N/A
			5000 API 6A	N/A	345
2500 API 6D	420	N/A	2500 API 6D	420	N/A
			10000 API 6A	N/A	690
2000 API 6A		138	2000 - 3000 API 6A	N/A	138 - 207
			900 - 1500 API 6D	150 - 260	N/A
3000 API 6A		207	3000 - 5000 API 6A	N/A	207 - 345
			1500 - 2500 API 6D	260 - 420	N/A
5000 API 6A		345	5000 - 10000 API 6A	N/A	345 - 690
			2500 API 6D	420	N/A
10000 API 6A		690	10000 - 15000	N/A	690 - 1034
			20000 API 6A		1379

## GALLI&CASSINA in the World

**Our products are being used in the most important Plants and Gas Pipelines all over the world.**

*Galli&Cassina Plug Valves are used in the most important hydrocarbon plants and gas pipelines all over the world.*

*For over 70 years Galli&Cassina has been committed to provide service to the end-users with a full range of products ensuring total customer's satisfaction.*

*Galli&Cassina is represented by sales offices worldwide and you are requested to contact our main office in Italy for more details.*



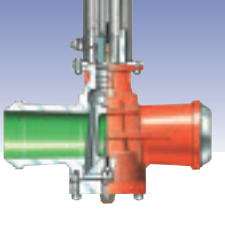
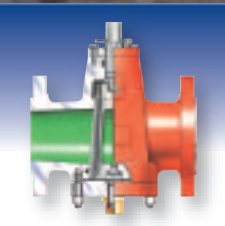
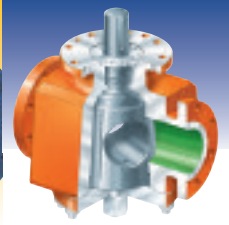
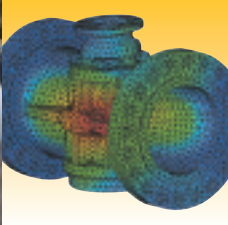

G&C DBB-10.2012





**GALLI & CASSINA**  
*Plus Valves*  
 SINCE 1919

**Office and Workshop:**  
 GALLI & CASSINA S.p.A.  
 Via Drizza, 30/32 • 20020 SOLARO (MILANO) Italy  
 Phone: +39.02.96799632/3 • Telefax: +39.02.96799699  
<http://www.gallicassina.it> • E-mail: [valves@gallicassina.it](mailto:valves@gallicassina.it)

